



# **HYDRAULIC EXCAVATOR**

**YC20SR / YC18SR**

**U20 / U18**

# **OPERATION MANUAL**

**GUANGXI YUCHAI HEAVY INDUSTRY COMPANY LIMITED**

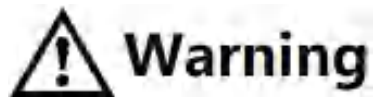

It is particularly important that the operator should read these instructions carefully in order to operate and maintain the excavator safely and correctly. Otherwise accidents or damage may occur.

- Remember the safety procedures and proper use of the machine.
- Read and understand the instructions for the safe operation of the machine.
- Understand and be familiar with all safety signs on the machine.
- Make sure that nobody unrelated to the job is at the work site.
- Operators should have been trained in the safe operation of the machine before operating the machine at the work site.

You are responsible for complying with relevant laws and regulations and following Yuchai Heavy Industries' instructions on machine operation and maintenance.

## CATALOGUE

1.	Foreword .....	1
1.1.	To Users .....	1
1.2.	Machine information .....	2
1.3.	Machine directions .....	4
1.4.	Machine components .....	5
1.5.	General Operation Information .....	6
1.5.1.	Specified operations .....	6
1.5.2.	Break-in .....	6
1.6.	Safety-related information .....	6
1.7.	Technical specifications .....	8
1.7.1.	Dimension paragauges .....	8
1.7.2.	Working paragauges .....	9
1.7.3.	Traveling mechanism .....	10
1.7.4.	Hydraulic system .....	10
1.7.5.	Electric system .....	10
1.7.6.	Working condition .....	10
1.7.7.	Interference .....	11
2.	Safety rules .....	12
2.1.	General safety rules .....	12
2.2.	Safety labels and instructions .....	13
2.3.	Safety equipment .....	13
2.4.	Security Signs .....	14
2.4.1.	Classification of safety signs .....	14
2.4.2.	Location of safety Signs .....	15
2.4.3.	Safety signs and descripton .....	16
2.5.	Workplace safety .....	20
2.6.	Safe Operations .....	21
2.6.1.	Start the engine .....	21
2.6.2.	Travel and Swinging .....	22

2.6.3.	Safety rules when traveling.....	23
2.6.4.	Traveling or working on slopes .....	23
2.6.5.	Safe excavation operations.....	26
2.6.6.	Tip and Skipping Prevention and Countermeasures .....	30
2.6.7.	Transportation and Handling .....	31
2.6.8.	Downtime maintenance .....	32
2.6.9.	Fire, Explosion and Poisoning Prevention .....	33
2.6.10.	Battery.....	35
2.6.11.	Hydraulic system.....	36
3.	Introduction of Components .....	40
3.1.	Control Consoles .....	40
3.2.	Safety locking components .....	41
3.3.	Switch assembly .....	42
3.4.	Electronics Controls.....	43
3.4.1.	Key (start switch operation).....	43
3.4.2.	Cigarette lighter .....	44
3.5.	Monitor .....	44
3.6.	Work device s and Swing Controls .....	45
3.7.	Travel control .....	46
3.8.	Throttle handle and stop handle .....	46
3.9.	Driver's Seat.....	47
3.10.	Seat belt.....	47
4.	Operation Instructions .....	49
4.1.	Preparation before operating the machine .....	49
4.2.	Engine Operation.....	50
4.2.1.	Check before starting the engine .....	50
4.2.2.	Starting the engine .....	51
4.2.3.	After starting the engine .....	54
4.2.4.	Shut down the engine .....	54
4.2.5.	Check after turning off the engine.....	55

4.3.	Enter and exit the machine .....	55
4.4.	Traveling.....	56
4.4.1.	Safety principles for traveling .....	56
4.4.2.	Preparation for traveling .....	57
4.4.3.	Travel forward.....	57
4.4.4.	Travel backward .....	58
4.4.5.	Stop the machine .....	58
4.5.	Steering .....	59
4.5.1.	Turning when the machine is stopped .....	59
4.6.	Rotation.....	60
4.7.	Working device Operations.....	60
4.7.1.	Arm control.....	60
4.7.2.	Rotation control .....	61
4.7.3.	Boom control.....	61
4.7.4.	Bucket control .....	61
4.7.5.	Boom deflection control .....	61
4.7.6.	Dozer blade control.....	61
4.8.	Working on slope or water .....	62
4.8.1.	Slope.....	62
4.9.	Getting out of the Muddy Environment .....	63
4.10.	General Operations instruction .....	64
4.10.1.	Backhoe operation.....	64
4.10.2.	Loading operation .....	64
4.10.3.	Trenching operations .....	65
4.10.4.	Backfilling or grading .....	65
4.10.5.	Shake off the soil stuck in the bucket.....	65
4.10.6.	Precautions for the use of related parts .....	65
4.11.	Removal and installation of bucket .....	66
4.12.	Disassembly .....	67
4.13.	Parking.....	68

4.14.	After operation.....	69
4.14.1.	Check .....	69
4.14.2.	Lock up .....	69
4.15.	Loading and unloading and transportation.....	69
4.15.1.	Safety rules .....	69
4.15.2.	Loading.....	70
4.15.3.	Fixing the machine on the transport vehicle .....	72
4.15.4.	Unloading from the transport vehicle .....	72
4.15.5.	Lifting machine.....	73
4.16.	Operation in cold/hot climate.....	74
4.16.1.	Operation in cold climate .....	74
4.16.2.	Operating in hot weather .....	75
4.17.	Storage of the machine .....	76
4.17.1.	Preparation before storage.....	76
4.17.2.	During storage.....	77
4.17.3.	Returning to work after storage .....	77
4.18.	Causes of technical failures and solutions .....	78
5.	Maintenance .....	85
5.1.	General knowledge of maintenance .....	85
5.1.1.	New machine break-in .....	85
5.1.2.	Working in dusty sites.....	85
5.1.3.	Oil and Filter .....	85
5.1.4.	Timer Readings.....	86
5.1.5.	Use genuine parts .....	86
5.1.6.	Waste disposal.....	86
5.1.7.	Prevent objects from falling into the machine.....	86
5.1.8.	Periodic inspection and maintenance.....	87
5.1.9.	Review after inspection and maintenance .....	87
5.2.	Maintenance Summary.....	88
5.2.1.	Lubricant .....	88

5.2.2.	Fuel .....	88
5.2.3.	Grease .....	88
5.2.4.	Coolant.....	89
5.2.5.	Filter element.....	89
5.2.6.	Hydraulic system.....	89
5.2.7.	Electrical System.....	90
5.3.	Wear and tear parts.....	90
5.4.	Mandatory replacement parts.....	91
5.5.	Oil selection table.....	92
5.6.	Tightening Torque.....	93
5.6.1.	Tightening torque for general parts.....	93
5.6.2.	Tightening torque for hydraulic Hoses.....	94
5.7.	Periodic Inspection and Maintenance Table .....	96
5.8.	General checking.....	98
5.9.	Engine Fuel System .....	98
5.9.1.	Oil level check and refueling.....	98
5.9.2.	Drain water and contaminants from the tank.....	99
5.9.3.	Cleaning the fuel tank .....	99
5.9.4.	Check the injection pressure.....	99
5.9.5.	Vent air from fuel circuit.....	100
5.9.6.	Changing the fuel filter .....	100
5.9.7.	Replace the fuel filter .....	101
5.10.	Engine Cooling System.....	101
5.10.1.	Check the coolant level.....	102
5.10.2.	Check the condition of the rubber hoses and clamps.....	102
5.10.3.	Clean and inspect the radiator blades .....	103
5.10.4.	Coolant replacement.....	103
5.10.5.	Check the coolant concentration.....	104
5.11.	Engine Lubrication System .....	104
5.11.1.	Oil level check .....	105

5.11.2.	Change the engine oil.....	105
5.11.3.	Replace the engine oil filter element .....	106
5.11.4.	Oil filter replacement.....	106
5.12.	Engine air intake system .....	106
5.12.1.	Cleaning of dust collection bin .....	107
5.12.2.	Clean the air filter element.....	107
5.12.3.	Replace the air filter element.....	108
5.12.4.	Check the air inlet pipe .....	108
5.13.	Other engine maintenance.....	108
5.14.	Hydraulic system .....	109
5.14.1.	Check the oil level in the hydraulic oil tank .....	110
5.14.2.	Drain the water and dirt in the hydraulic oil tank .....	111
5.14.3.	Replace the hydraulic oil and clean the oil suction filter .....	111
5.14.4.	Vent air from the hydraulic system.....	113
5.14.5.	Replace the return oil filter element.....	115
5.14.6.	Replace the pilot oil filter element .....	116
5.15.	Battery .....	117
5.15.1.	Storage of battery .....	118
5.15.2.	Charging of the battery .....	118
5.15.3.	Installation of the battery.....	119
5.15.4.	Battery maintenance .....	120
5.16.	Speed Reducer .....	120
5.16.1.	Traveling reducer .....	121
5.16.2.	Replace the lubricant (for each gearbox).....	121
5.16.3.	Check the tightening torque of the bolts connecting the travel reducer and the slewing reducer	122
5.16.4.	Check the solidity of the connecting bolts of the slewing reducer .....	122
5.16.5.	Tracks.....	122
5.17.	Idler wheel and guide wheel.....	124
5.18.	Lubrication .....	124
5.19.	Replacement of bucket teeth .....	126



5.20.	Flushing of the floor mat.....	127
<b>6.</b>	<b>Attachment Guide.....</b>	<b>128</b>
6.1.	Safety issues.....	128
6.1.1.	Safe operation of attachments .....	129
6.2.	Removing or installing attachments.....	130
6.2.1.	Attachment Installation/Removal Procedure .....	130
6.3.	Attachment Operation Guide.....	131
6.3.1.	Hydraulic Hammer.....	132
6.4.	Daily inspection of hydraulic hammer .....	135
6.5.	Quick coupler.....	136
6.6.	Grab Bucket.....	137
6.6.1.	Installation of grab bucket.....	137
6.6.2.	Operation of the grab bucket .....	138
6.6.3.	Operation precautions of the grapple.....	138
6.6.4.	Maintenance of the grapple.....	140
6.7.	Drilling device.....	140
6.7.1.	Installation of drilling device.....	140
6.7.2.	Operation of the drilling unit.....	141
6.7.3.	Precautions for the operation of drilling device .....	141
6.8.	Backhoe bucket with scraper .....	142
6.8.1.	Installation.....	142
6.8.2.	Operation of the backhoe bucket .....	143
6.8.3.	Maintenance of the backhoe bucket.....	143

# 1. Foreword

## 1.1. To Users

Dear users.

Greetings!

Welcome to use Yuchai excavator and thank you for your great support to Yuchai business.

This manual is intended as a safety guide and for the proper use and maintenance of the machine. Before starting and operating the machine for the first time and before servicing the machine, please make sure to read and understand this manual carefully and fully understand the safety procedures, operation and maintenance procedures. For easy access, keep this manual in a safe place so it can be read regularly by qualified machine operators. If this manual is lost, damaged or illegible, please order it immediately from our company or dealer. When transferring the machine, please pass this manual along with it so the next owner can use it properly.

Please entrust the overhaul and adjustment of the machine to Yuchai Heavy Industry's dealer or service station, and use original parts and spare parts provided by our company. If you use non-original parts or components, they may not have an obvious effect on the machine at the time, but may cause problems later. Yuchai Heavy Industry will not undertake the warranty service even if the machine breaks down during the warranty period due to the use of non-original parts or components or the maintenance is done by unauthorized organizations.

Based on the principle of "customer first", Yuchai Heavy Industry continuously improves its products in order to provide the best possible products to customers, for which improvements may be implemented at any time. For the products being sold at that time, we do not replace the information and do not give any advance notice.

We sincerely hope that this machine will serve you better and create more value with your proper use and careful care.

## 1.2. Machine information

When you need to know the basic information of the machine, you can view it in the position shown in the picture.

- Machine information (Nameplate is located on the right front side of the upper machine)

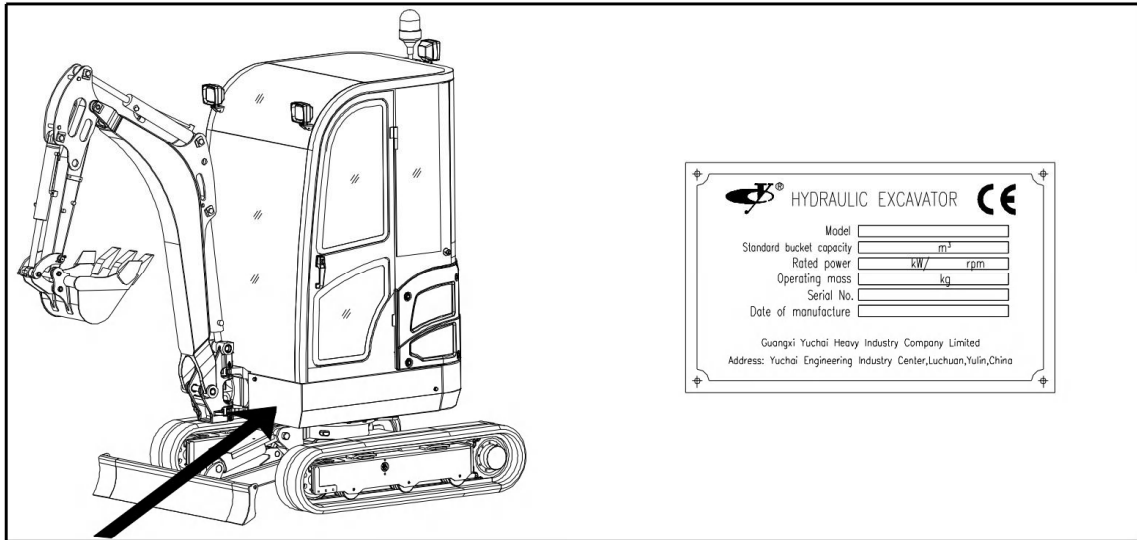

- Engine Information

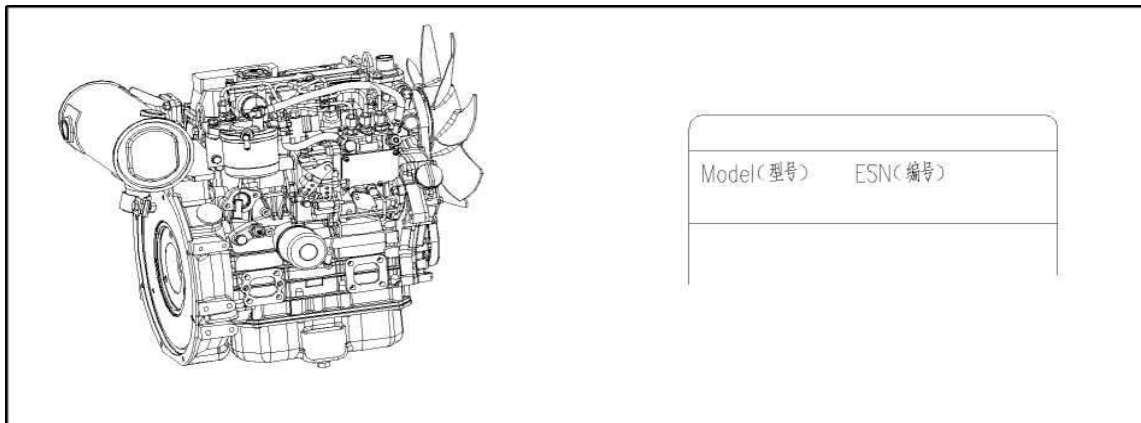

- Machine operation information (engine timer is located on the monitor in the right joystick box)

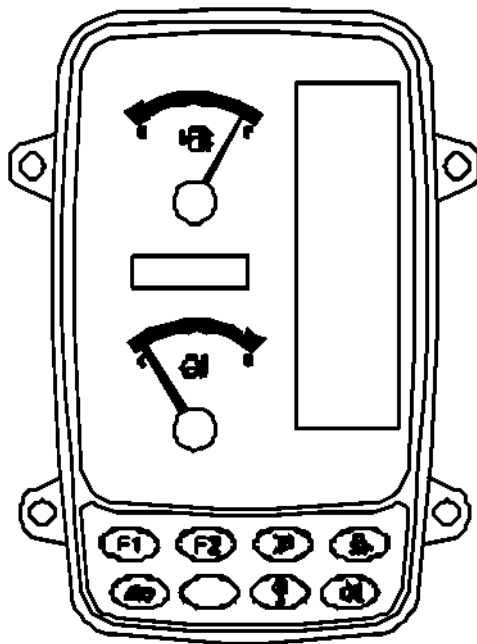

**Machine Archives**

Fill in the form below with the VIN and engine number of your machine. You can provide them to Yuchai when you need to purchase spare parts or request relevant information.

Please record these numbers and keep them together with the product certificate. If your machine is stolen, you can submit them to police.

	<ul style="list-style-type: none"><li>● MODEL:</li><li>● SERIAL NUMBER:</li><li>● ENGINE SERIAL NUMBER:</li><li>● DEALER:</li></ul>
--	---

### 1.3. Machine directions

The front, back, left, right, top and bottom on this manual refer to each direction of the illustrated pictures.

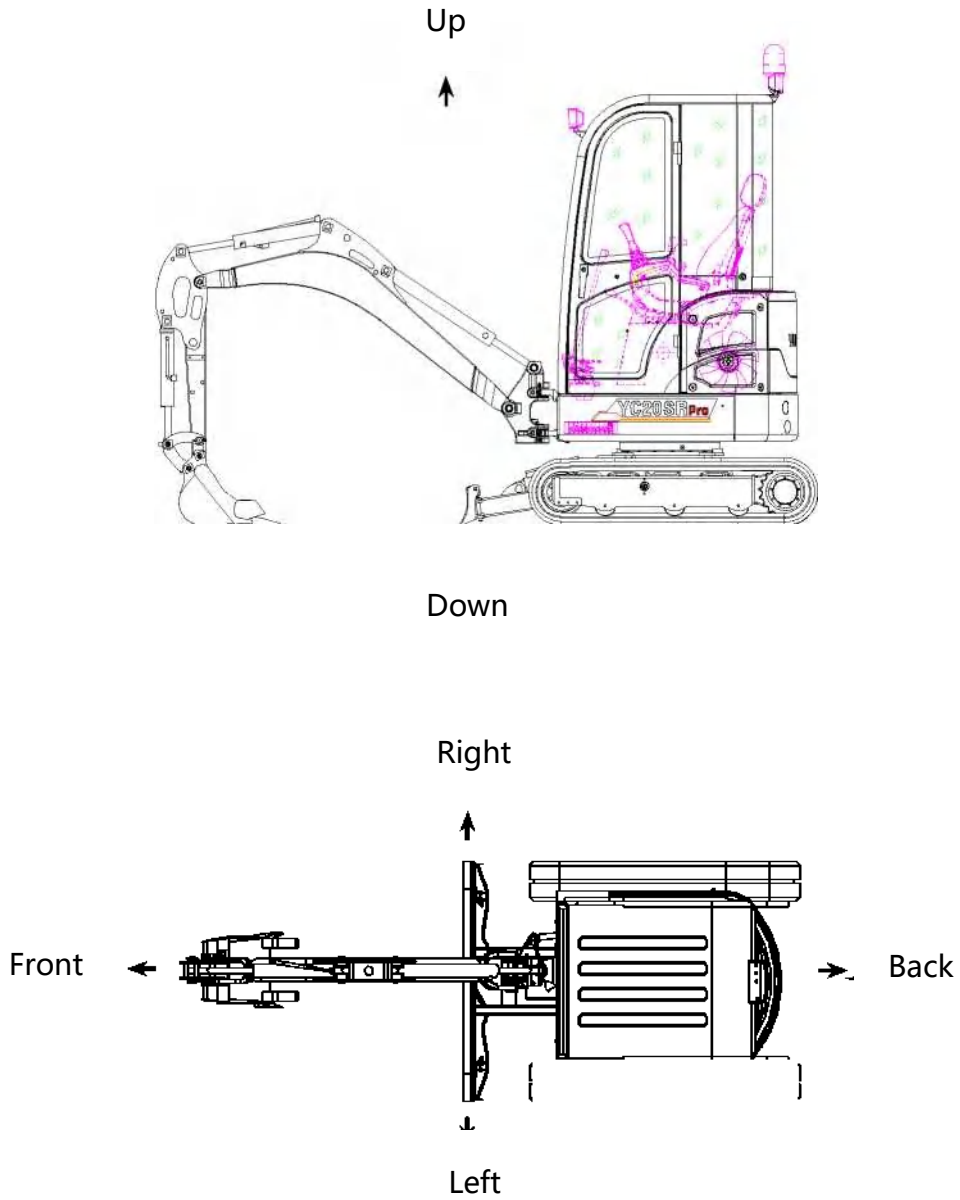

## 1.4. Machine components

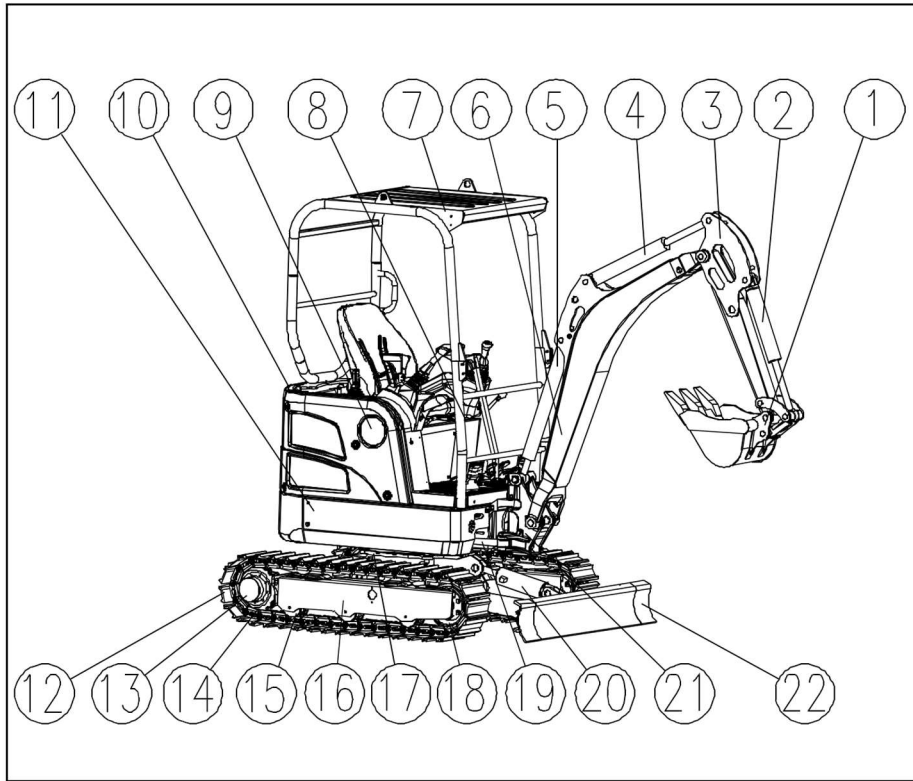

1	Bucket	12	Tracks
2	Bucket Cylinder	13	Travel Reducer
3	Arm	14	Driving Roller
4	Arm Cylinder	15	Carrier Roller
5	Boom Cylinder	16	Chassis
6	Boom	17	Slew Ring
7	Cab	18	Idler
8	Hydraulic Tank	19	Boom Swing Cylinder
9	Fuel Tank	20	Dozer Blade Cylinder
10	Rear Panel	21	Boom Swing Knuckle
11	Upper Platform	22	Dozer

## 1.5. General Operation Information

### 1.5.1. Specified operations

This machine is mainly used for the following operations.

- Digging
- Trenching
- Loading
- Grading

Please refer to operation guide and attachment guide for detailed descriptions of the operating principles.

### 1.5.2. Break-in

The machine has been fully adjusted and checked before delivery. If the machine is operated at full load from beginning, it will accelerate the degradation of performance and shorten the service life of the machine. Therefore, for the first 100 hours (the time displayed on the gauge), please limit the load to 80% of the full load during break-in period.

## 1.6. Safety-related information



Most of the accidents related to operation, inspection, maintenance and repair work are caused by negligence of basic safety precautions and hazard prediction.

By anticipating the conditions where hazards may occur, accidents can be prevented. Therefore, it is important to be aware of the location and type of hazards. (In order to do so, operators must have the required training, skills, and tools.)

Read and understand all safety precautions, WARNINGS and accident prevention methods described in this manual and on the machine. Otherwise you should never operate and inspect the machine. If these WARNINGS are ignored, injury or death may result.

The safety instructions in this manual and the safety signs used on this machine distinguish the level of danger that may occur by the following WARNINGS. Precautions to avoid hazards are also included.

-  **Danger: Indicates that if not avoided, the consequences of the hazard will result in death or serious injury and is only applicable to the few occasions when the greatest danger exists.**

-  **WARNING: Indicates that the consequences of the potential hazard may result in death or serious injury if not avoided.**
-  **CAUTION: Indicates that the consequences of a potential hazard may result in a low or moderate level of injury if not avoided, and may also be used to indicate unsafe practices that may result in injury.**

We cannot predict all hazards of operation, inspection, maintenance and repair in all environments. Therefore, the WARNINGS indicated in this manual and on the machine do not cover all situations. During operation, inspection, maintenance and repair operations that are not covered in this manual, user is requested to follow the necessary safety precautions. It is the responsibility of the user to take the necessary safety precautions.



## 1.7. Technical specifications

### 1.7.1. Dimension paragauges

	Items	Unit	YC20SR (E20F51S)
	Working weight	Kg	2000 (cabin, rubber track)
	Bucket capacity	m <sup>3</sup>	0.05
	Engine model		Yanmar 3TNV76-P
	Engine power	kw/rpm	14.5/2400
A	Overall length (transportation status)	mm	3750
B	Total length of grounding		2650
C	Working device height (to the top of boom)	mm	1150
D	Overall width	mm	1080
E	Over all height (transportation status)	mm	2345
F	Ground clearance of platform	mm	465
G	Min. ground clearance of chassis	mm	145
H	Tail slewing radius	mm	700
I	Track grounding length	mm	1230
J	Track length	mm	1600
K	Gauge	mm	850/1170
L	Width of chassis	mm	1080/1400
M	Width of track	mm	230
O	Height of engine hood	mm	1265
P	Length from slewing center to tail	mm	700
	Max. slewing speed	Rpm	8.5~10.5
	Traveling speed	km/h	2 / 4

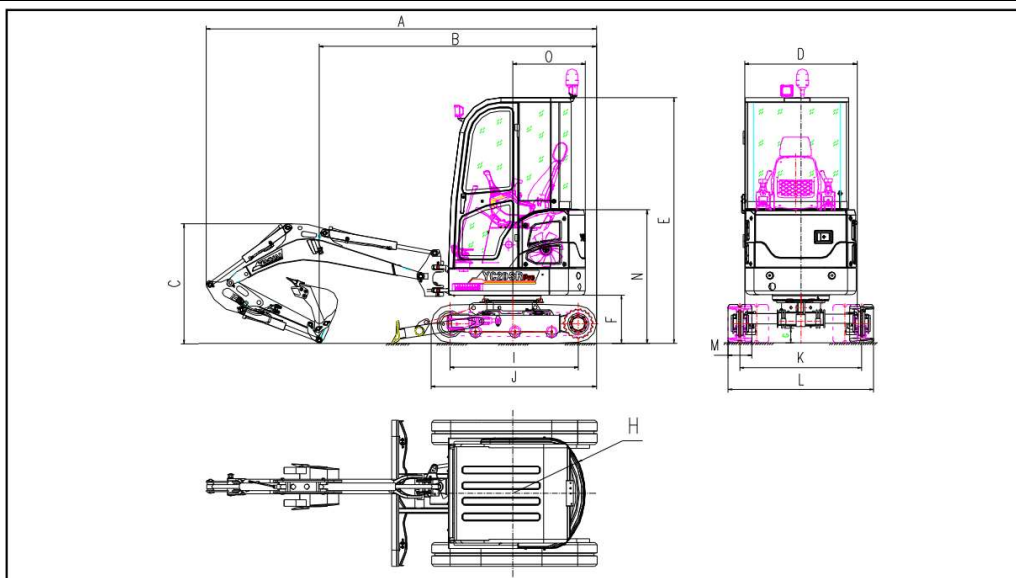

Specifications are subject to change without prior notice

### 1.7.2. Working paragauges

	Items	Unit	YC20SR (E20F51S)
AA	Max. digging height	mm	3600
BB	Max. dumping height	mm	2485
CC	Max. digging depth	mm	2310
DD	Max. vertical digging depth	mm	1920
EE	working device Min. slewing radius	mm	1690
FF	Max. digging radius on ground level	mm	4060
GG	Max. digging radius	mm	4125
HH	Max. lifting height of dozer blade	mm	245
JJ	Maximum bulldozing depth	mm	245
	Max. digging force of bucket	KN	15.5
	Max. digging force of arm	KN	8.5
	offset boom Max. left swing angle	°	55
	offset boom Max. right swing angle	°	65

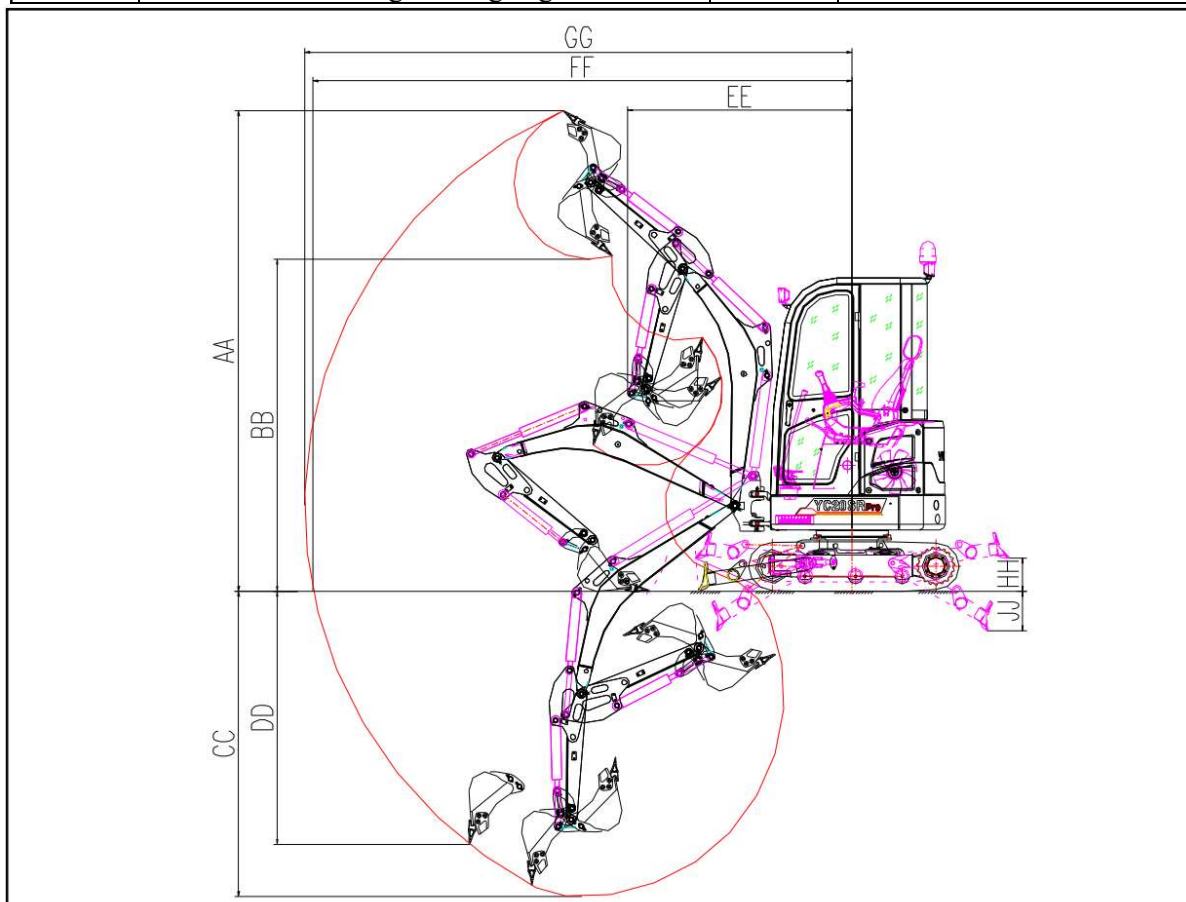

Specifications are subject to change without prior notice

### 1.7.3. Traveling mechanism

The traveling system is driven by hydraulic motor through multistage planetary reducer.

	Traveling speed	Gradeability
High speed	4	58%(30°)
Low speed	2	

### 1.7.4. Hydraulic system

Load sensing hydraulic system.

Max. hydraulic flow rate: 61.6L/min (2200 rpm)

Working pressure: 24 Mpa (LS=21.5 Mpa, load compensated pressure difference 2.5 Mpa)

Slewing pressure: 9 Mpa

Auxiliary pipe 1 / Auxiliary pipe 2 pressure: 21 Mpa

Pilot pressure: 3.5 Mpa

Oil return filter: 10 μm

Oil intake filter: metal filter

### 1.7.5. Electric system

Voltage: 12V

Battery: 45 AH

### 1.7.6. Working condition

Temperature: -15~40°C

Humidity: <85%

Altitude: ≤1500m

Transportation and storage temperature: -15~40°C

### 1.7.7. Interference

Non-standard working devices may interfere with the boom cylinder or the lower cover of the boom. When non-standard working devices are used, attention should be paid to the angle between the boom and the boom when retrieving the bucket to prevent interference with the boom cylinder and damage to the machine body.

The following are all the non-standard attachment work devices that we offer.

Buckets	Bucket attachments mounted directly on the boom
	Bucket attachment with quick connector
	Bucket attachment mounted on quick couple
Rock breaker	Directly mounted on the boom
	Crushing hammers mounted on quick couple
Auger	Auger mounted on the boom directly
	Auger mounted on quick couple
Grab	Grabs directly mounted on booms

If you buy a model with any of the above attachments, you need to pay attention to the above mentioned issues.

## **2. Safety rules**

### **2.1. General safety rules**

Following the relevant safety procedures in this manual will prevent most accidents , avoiding endangering operation and maintenance of the machine. Before you operate or service the machine, you should read and understand all the safety information in this book and on the decals for the machine.

The safety instruction in this manual listed the situations may occur during normal operation and maintenance of the machine and give corresponding handling methods.

The safety instruction are described in this chapter and safety related materials in other chapters.

The safety information in this manual and on the machine does not cover all potential hazards and possible countermeasures. If methods or actions are used that are not recommended or permitted in this manual and on the machine, it is your responsibility to take the necessary measures to ensure safety.

Under no circumstances operators can perform any actions prohibited by the instructions in this book.

The excavator should be operated and maintained by trained and qualified personnel.

Before starting to work, check all functions of the machine. If the machine is not working properly, stop immediately to find out the cause of the problem, and work only after solving the problem.

The inspection, maintenance and repair should be carried out in strict accordance with the provisions of this manual, and the operator should work and operate the machine in accordance with the operating methods, safety regulations and the scope of work of the machine as specified in this manual.

If you are under the influence of alcohol or drugs, do not operate or maintain the machine, this is very dangerous.

You must understand the content of the relevant signals and hand signals.

When traveling on public road, you must be familiar with the relevant laws and regulations of your country or region, and strictly comply with them.

Please make sure that there is no other person in the working area before operating the machine.

The machine is only used for normal excavation work on the ground. Do not use it in

dangerous work conditions such as underwater, culverts, explosive places and toxic environments.

## 2.2. Safety labels and instructions



### 2.2.1. WARNING Symbols

In this manual, WARNING sign indicates important information about safety. Seeing this sign, you should read the information and advice in it carefully to avoid injury.

### 2.2.2. Safety WARNINGS

The safety instructions in this manual and the safety signs used on this machine distinguish the level of danger that may occur by the following WARNINGS. Precautions to avoid hazards are also included.

The machine's safety instructions are indicated by the words **"DANGER"**, **"WARNING" or "CAUTION"**. The following are their corresponding explanations.

-  **DANGER: Indicates that if not avoided, the consequences of the hazard will result in death or serious injury and is only applicable to the few occasions when the greatest danger exists.**
-  **WARNING: Indicates that the consequences of the potential hazard may result in death or serious injury if not avoided.**
-  **CAUTION: Indicates that the consequences of a potential hazard may result in a low or moderate level of injury if not avoided, and may also be used to indicate unsafe practices that may result in injury.**

## 2.3. Safety equipment

Protective equipment for operators

### ➤ Clothes

The operator must wear tight-fitting work clothes, helmet, work shoes and other protective equipment (e.g., ear plugs, gloves, protective glasses, safety belt, etc.) before operation or maintenance.

### ➤ Hair

If the operator's hair is too long, please tie it up and cover it with a helmet to avoid getting tangled in the machine.

➤ **First aid**

The user must provide first-aid medicine in the machine, check it regularly, and add medicine when necessary in case of emergency.

➤ **check**

Please make sure to check the function of all protective equipment before operation or maintenance.

## 2.4. Security Signs



**WARNING: Failure to read or loss of safety signs may result in injury or death.**  
**Replace missing or damaged signs promptly and keep them clean and legible.**

Before operating, maintaining or servicing the machine, you must read and understand the manual and the WARNING signs on the machine and follow the relevant procedures.

Check the signs before starting the machine every day to make sure they are clean and legible.

When cleaning the signs, use only cotton cloth, water and soap. Do not use organic solvents and gasoline, etc.

If the sign is broken, lost or unreadable, replace it. If the marker is located on a part that needs to be replaced, make sure that the marker is matched on the new part.

Please contact Yuchai agent to obtain new safety markings.

### 2.4.1. Classification of safety signs

Safety signs used in this manual and on the machine are "graphic safety signs" and "graphic+text safety signs"

#### **A. Graphic safety sign**

This type of safety marking is a graphic representation of the safety WARNING information, easy to understand.



## **B. Graphic+text safety signs**

This type of safety sign has a diagram and corresponding explanatory text, and is used where the graphic does not adequately convey the safety message.

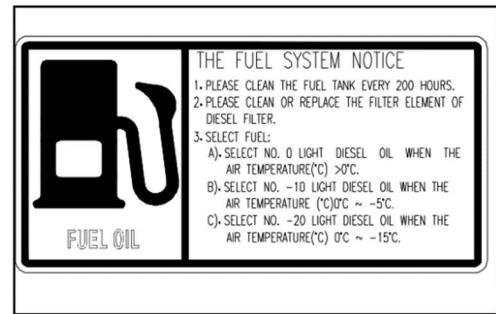

### **2.4.2. Location of safety Signs**

The sign shown is only the "safety signs", other type of signs logos are described in later sections.

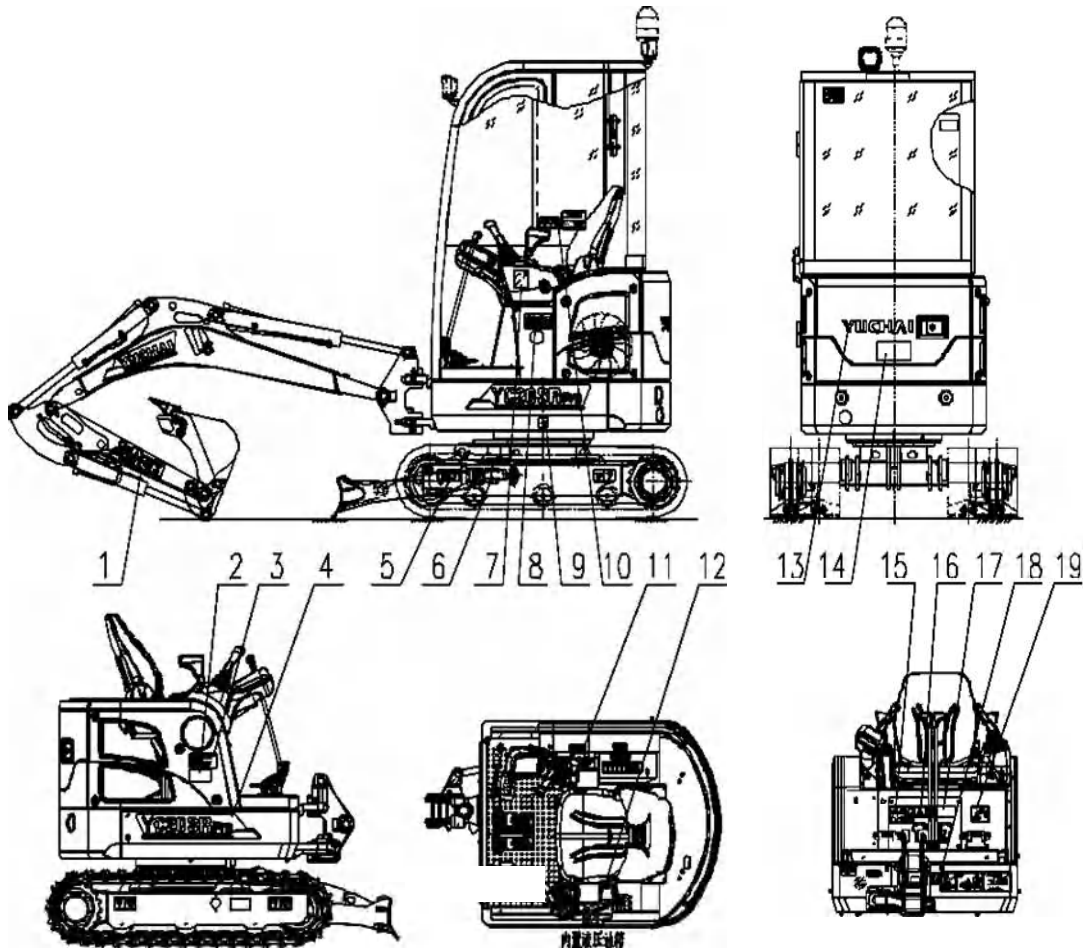



### 2.4.3. Safety signs and descripton

- Stay away from the working device

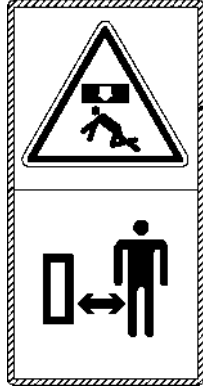

Moving work equipment can cause injury. Keep a safe distance from the area where the work device is working.

- Warning signs

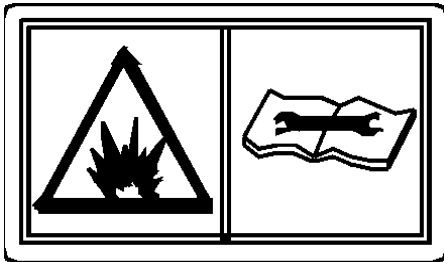

- Fuel oil inlet

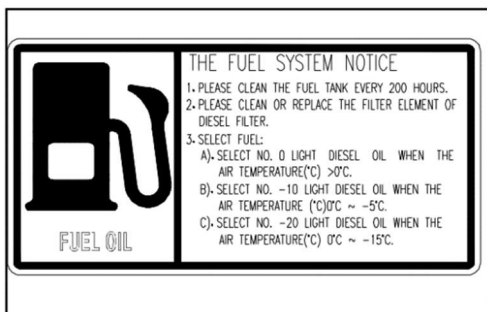

- left signs



- Lifting combination signs

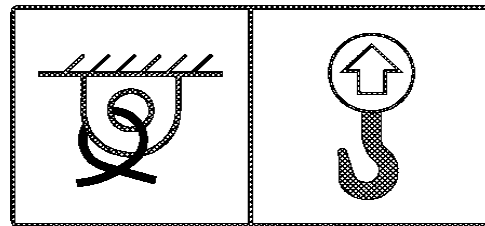

- Warning signs



- Safety switch signs

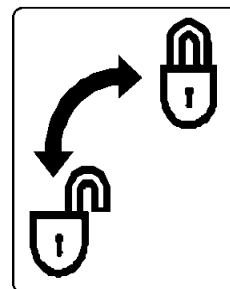

- Hydraulic oil refilling sign

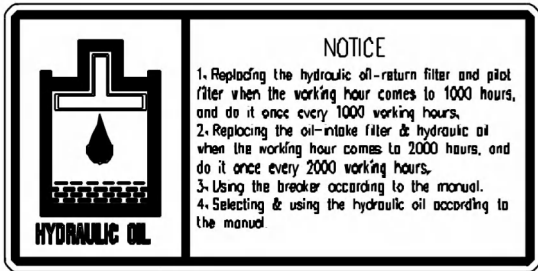

- Warning sign

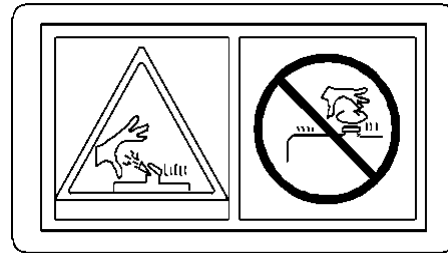

- Swing center

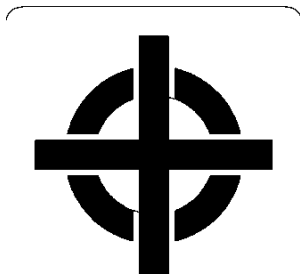

- Tail signs



- Control signs

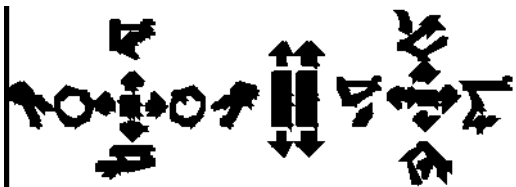

- Safety sign



- Throttle sign



- Warning sign

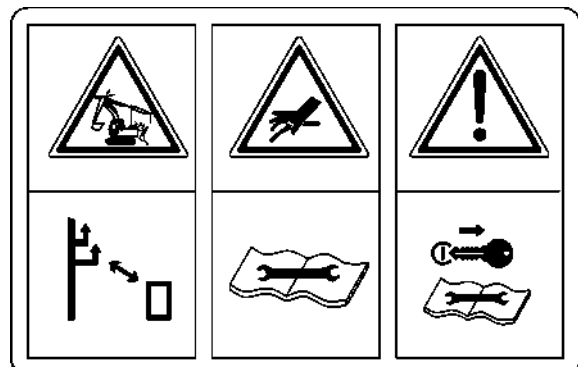

- **Warning sign**



- **Lubrication oil refill sign**

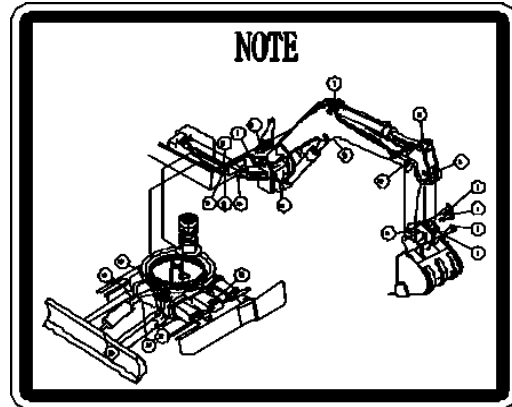

- **Reading manual sign**

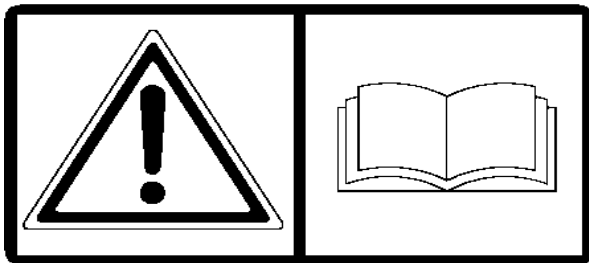

- **High temperature sign**



- **Machine Lift Points**

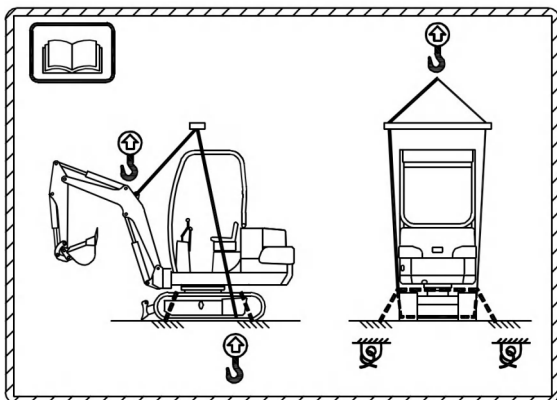

- **Stop engine sign**

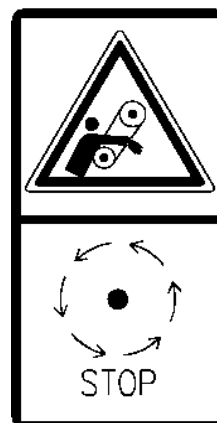

- **Warning sign**

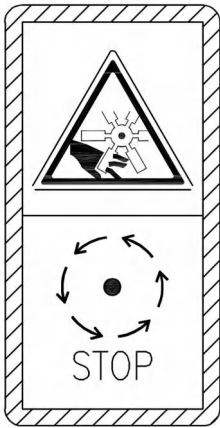

- **Maintenance warning**

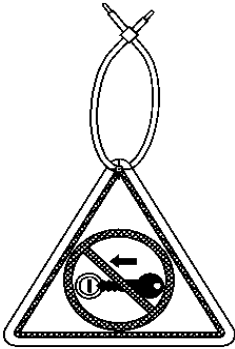

- **Swing lock sign**

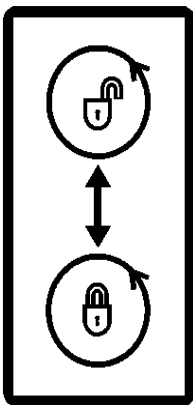

## 2.5. Workplace safety

**Familiarize yourself with the area you will be working in advance. Please check.**

- 1) Location of slopes.
- 2) Ditches.
- 3) Falling or hanging objects.
- 4) Soil conditions (soft or hard).
- 5) Stagnant water and swampy areas.
- 6) Tocks and tree stumps.
- 7) Boundaries of buried foundations, root posts or walls.
- 8) Boundaries of buried wastes or refills
- 9) Holes, obstructions, mud, or ice.
- 10) Traffic
- 11) Dense dust, smoke, and fog.
- 12) The exact location of buried or hanging electrical, gas, telephone, water, sewer, or other utility lines. If necessary, have the utility company mark, shut down or relocate these facilities before you begin work.

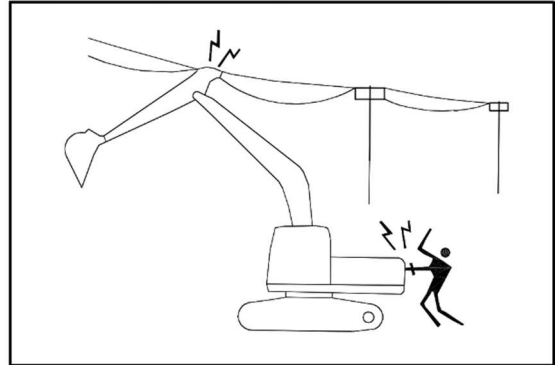

**WARNING: Contact your local utility service system and department before starting an excavation project.**

- 13) When working in a building, find out the overhead room, porches, aisles, etc. and the load-bearing capacity of floors and ramps. Ensure adequate ventilation when operating indoors. What you don't know can hurt you.
- 14) Know the ground clearance, the exact distance between the electrical and telephone lines and the machine. If possible, it is best to disconnect the power supply. If power cannot be disconnected, ask for a signalman to guide you.



**WARNING: Touching or being near a power source or near a machine connected to a power source can cause electric shock. Do not allow any part of the machine to come near an aerial power line unless the necessary safety precautions have been taken.**

15) Confirm the depth of underground gas pipes, cables, telephone lines and water pipes and avoid these areas when working



**WARNING: If you look in from the end of the damaged cable, the cut fiber will seriously hurt your eyes.**

16) It is forbidden to use this machine under the culverts.

17) It is forbidden to work in mud, mire and swamp.

18) It is forbidden to work in the place where there are chemical harmful substances.

19) It is forbidden to use in the occasion of explosion.

## 2.6. Safe Operations



**WARNING: It is strictly forbidden to carry or lift people with the excavator.**

**WARNING: Before operating the machine, you must fasten the safety belt, sound the horn and make sure no one is around the work area before starting to work.**

### 2.6.1. Start the engine

- Safety rules for starting the engine

1) Before starting the engine, sound the horn to warn.

2) No one other than the operator is allowed to be in the cab.

3) Sit on the seat when operate the machine.

4) Do not start the engine by short-circuiting the motor.

5) The machine must be warmed up in cold weather.

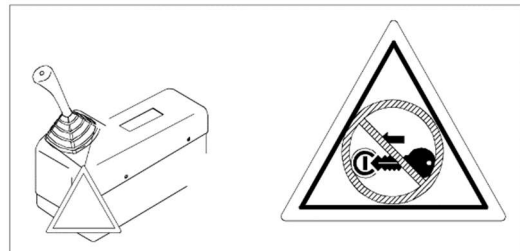

**WARNING: The engine is not allowed to be started when there is “ no engine start“ warning sign on the handle.**

- After the engine is started, check the following

- 1) Safety belt fastened properly.
- 2) The working device, bulldozing device, traveling, slewing, working device deflection and other moving parts work normal.
- 3) There is any abnormality in the sound, vibration, smell or gauge of the machine.
- 4) Oil or fuel leakage

### 2.6.2. Travel and Swinging

1) Before traveling, turn the upper platform to the proper position with the working device in the same direction as the dozer. If the working device is in the opposite direction of the dozer, the operation will be reversed.

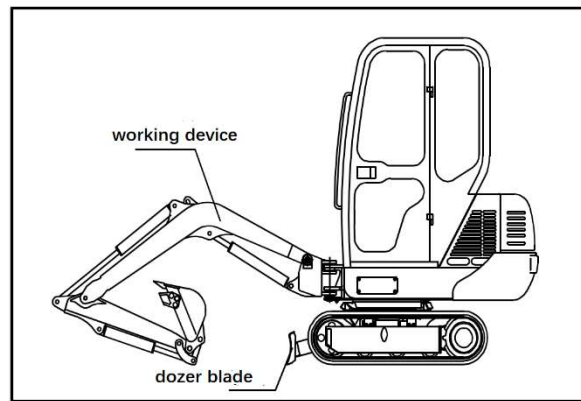

2) Sound the horn before traveling and slewing to warn people in the working area.

3) The excavator must travel and operate on solid ground of more than 1.5 times its width.

4) Before backing up and slewing, if there is visually blocked area, make sure a signal commander is at the site.

5) Before traveling, the cab door should be closed and locked, and the cab window, rollover window and sunroof are allowed to be opened, but must be secured.

### 2.6.3. Safety rules when traveling

- 1) When traveling on a flat road, the arm must be lowered and the boom retracted to maintain the best position of the center of gravity, and the distance between the bottom of the bucket and the ground should be 40 - 50 cm.

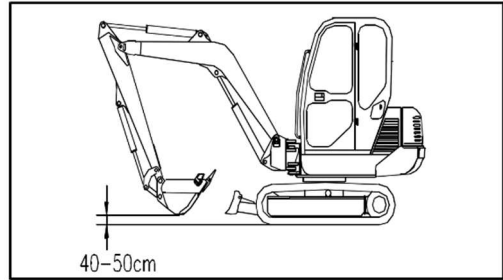

- 2) When traveling on rough and uneven road, use low speed and do not turn suddenly, otherwise machine may tip over and endanger the operator.

- 3) The machine should not travel on obstacles that lean to one side, which may cause the machine to tip over.

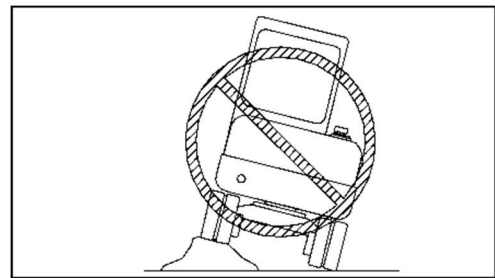

- 4) When traveling or operating, be sure to maintain a safe distance from people, buildings or other machines.

- 5) When traveling through underpasses, under bridges or under power lines and other places of limited height, use hand signals to direct. And be careful to maintain safe distance.

- 6) Always lock the platform when traveling up and down slopes.

- 7) When passing over bridges or buildings or supports, make sure that they are sufficient to support the weight of the machine.

- 8) When you want to travel on the road, consult the local traffic authorities first and get their permission before.

### 2.6.4. Traveling or working on slopes

Excavators traveling or operating on slopes are extremely dangerous and must be taken with special care.

- 1) It is recommended not to travel up and down long slopes greater than 20 degrees.



2) When the machine is working, especially when working up and down slopes and in dangerous areas, fasten the safety belt.

3) When the excavator is going up the slope, drive at low speed, the driving wheel should be in the lower direction of the slope, the arm and bucket should be fully extended parallel to the slope, and the bucket teeth should be 20-30cm away from the ground, and the platform should be locked.

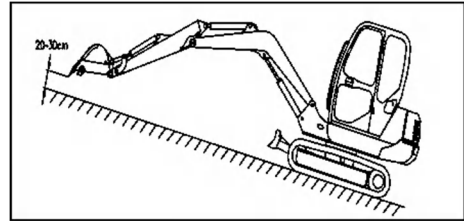

4) When the excavator is going downhill, the platform should be locked, the driving wheel should be in the direction of the slope, the arm and boom should be fully extended, and the bucket teeth should be 20-30cm away from the ground, and the slope should be downhill at low speed.

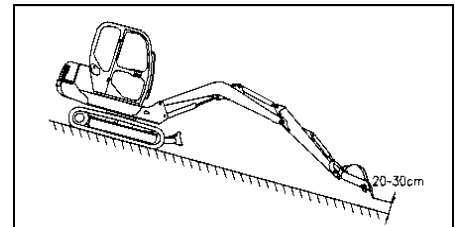

5) Do not turn on the slope or cross the slope. Be sure to go down to a flat place to change the position of the machine, and then go up the slope again.

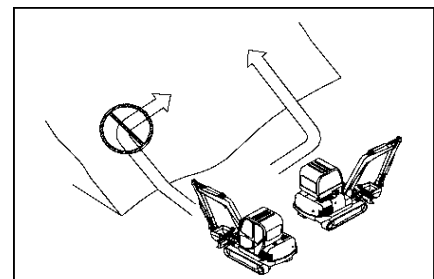

6) When working on a slope, start from a high place and dig gradually in the downhill direction, with the dozer at the rear and pressed against the ground. The drain position should be placed in the uphill direction.

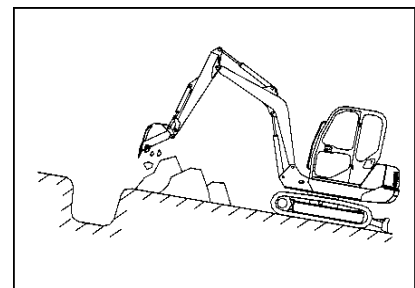

7) Travel at a low speed on grass, leaves or wet

steel sheets, because there is a danger of the machine slipping even on small slopes.

- 8) Never turn sharply on an uphill or downhill slope, otherwise the machine will tip over.
- 9) When stopping on a slope, the front dozer and the bucket must be inserted into the soil and the driver can get off the machine only after stopping the engine and the machine is safely parked.



**DANGER: Stopping on a slope is very dangerous! If it is unavoidable to do so, do the following: If the engine stalls on a slope, lower the bucket and dozer to the ground immediately and put all handles in the neutral position, then restart the engine. Even if the engine stops for a short time on a slope, lower the bucket and dozer to the ground and pull all handles to the neutral position, and place a secure obstacle at the lower end of the tracks.**

- 10) It is strictly forbidden to travel on the slope with the direction of longitudinal slope greater than 25 degrees

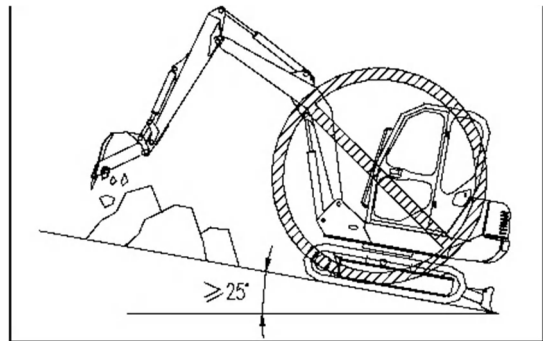

- 11) It is strictly forbidden to travel on slopes with a horizontal slope greater than 15 degrees.

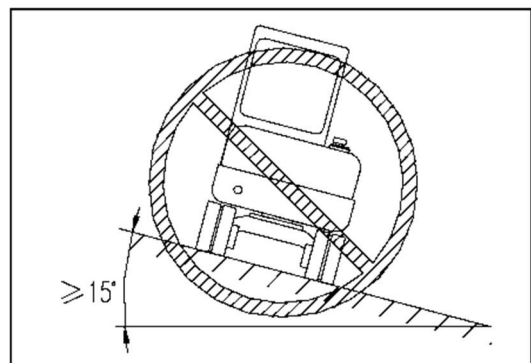

- 12) Try to keep the machine balanced, and forbid traveling on rocks or over obstacles.

- 13) Do not change direction on the slope.
- 14) When going up a slope, make sure the engine and hydraulic oil are properly warmed up, otherwise accidents may happen.

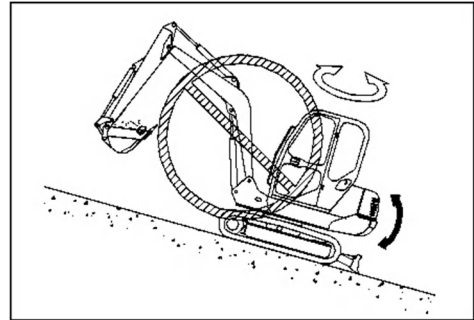

- 15) When the excavator is on a slope with two tracks oriented at 90 degrees to the slope, it is very dangerous to swing. When you have to swing, make the bucket is close to the ground and machine, with the tracks facing the direction of the top of the slope, and swing slowly.

- 16) When swing or maneuvering work device on a slope, there is a risk of the machine losing balance and tipping over. This can cause serious injury or equipment damage. So before operating, you should build up a strong platform with soil that can keep the machine level.

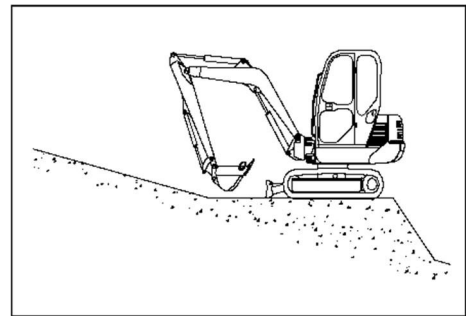

### 2.6.5. Safe excavation operations



**WARNING: The operator must be familiar with the functions of each operating lever .**

**WARNING: Improper use of the excavator can cause tipping or skidding, so memorizing this section to ensure your personal safety.**

- 1) Remove any unrelated persons from the excavation site before working.
- 2) Make sure the work site can adequately support the machine before driving in.
- 3) Keep both tracks of the excavator on the same level
- 4) Confirm that there is no cable, air pipe, water pipe under the work site, or have been clearly marked before digging.
- 5) When the machine travels backwards during excavation (such as digging a

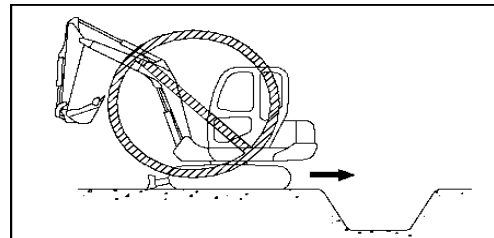

trench, etc.), make sure the path is level and clear.

- 6) When the bucket meets unyielding resistance, do not travel or rotate, otherwise the machine will be damaged.

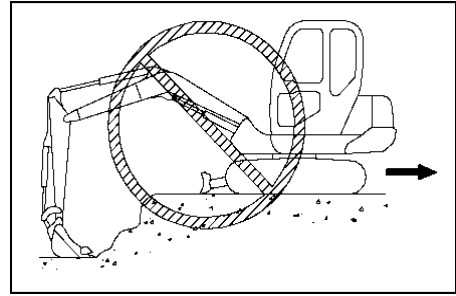

- 7) If the hydraulic cylinder is operated to the end of its stroke during operation, the force will push on the internal limit ring of the cylinder, thus reducing the life of the machine. Always operate the hydraulic cylinder with a small margin.

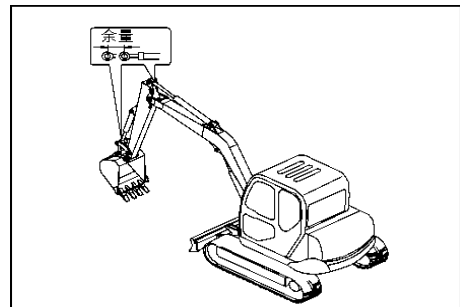

- 8) When digging deep, make sure the hoses under the arm or bucket do not touch the ground.

- 9) When operating the machine, avoid touching the boom, arm, bucket and cab with foreign objects.

- 10) When the machine is swinging, avoid touching the engine hood and rear counterweight.

- 11) When lowering the arm, try not stop suddenly

- 12) Do not dig into the body of the machine.

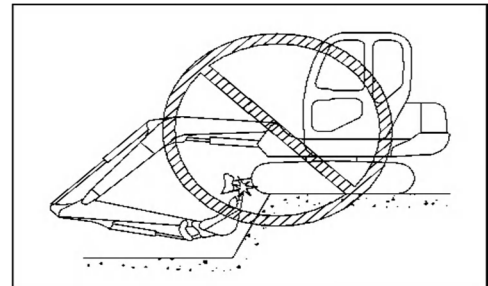

- 13) Do not excavate when the tracks are off the ground, otherwise the machine and structure will be damaged.

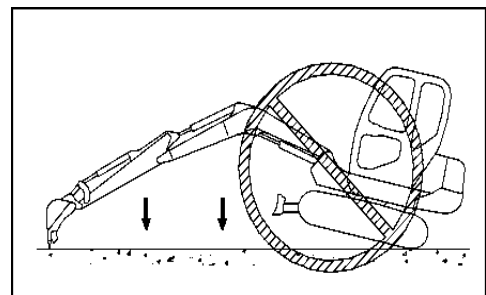

14) Do not use the weight of the machine to increase the digging force.

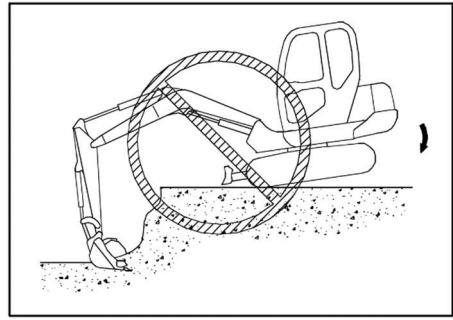

15) Do not use the bucket drop as a hand pick, crusher, or pile driver as this will overload the rear structure of the machine. This will not only damage the machine but is also very dangerous.

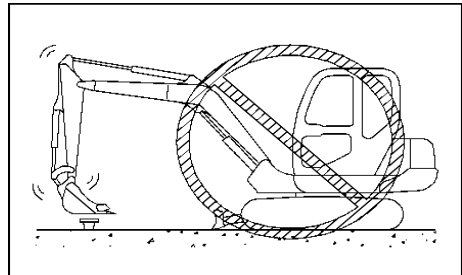

16) Do not overuse the bucket to level the road, otherwise the parts will be overloaded, and the machine will be damaged.

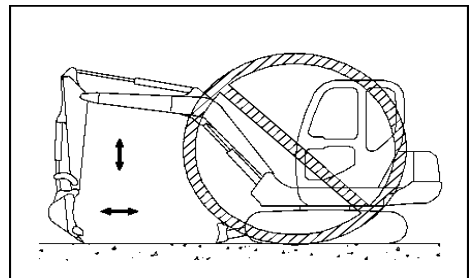

17) Do not use the falling force of the machine for digging, as this may damage the machine.

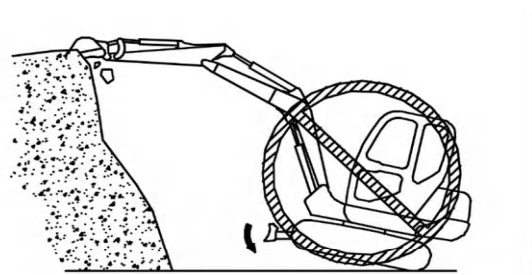
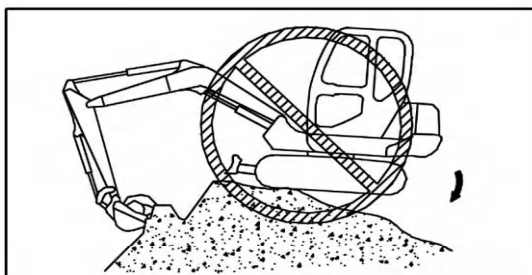

- 18) Do not use the rotary force to compact the soil or to damage mounds and walls. When turning, do not insert the bucket teeth into the soil, as these actions can damage the working device.

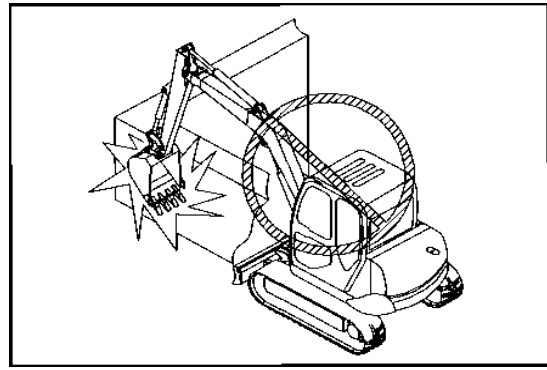

- 19) Do not dig into the ground with the bucket and use the traveling force to excavate, as this will cause the rear of the machine to be subjected to excessive forces.

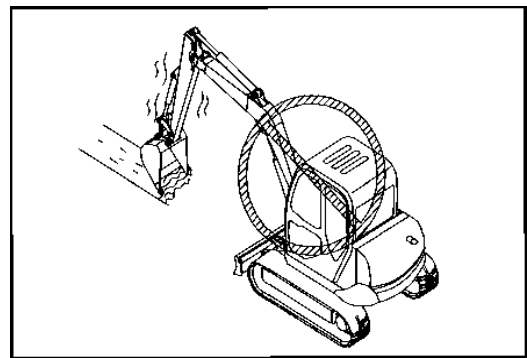

- 20) Do not excavate under the overhanging part, as there is a risk of falling rocks or of the overhanging part collapsing and hitting the machine.

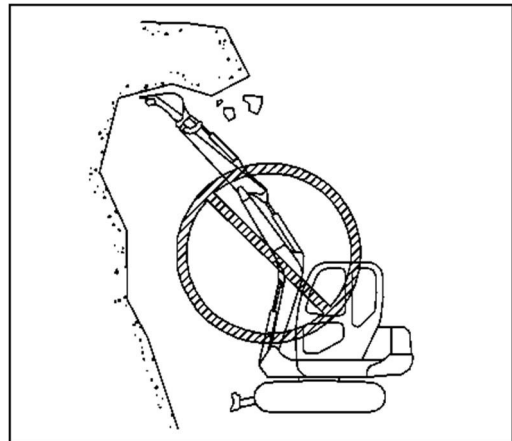

## 2.6.6. Tip and Skipping Prevention and Countermeasures

### **WARNING:**



1) **When you have to turn on the ramp, only turn in a big circle. When the machine is to turn to the right, extend the arm and boom to the left, with the bucket about 30cm from the ground, and lock the platform. And vice versa.**

2) **When the machine skids, press the dozer and bucket to the ground immediately.**

3) **When the machine is tipped, the driver should not jump out of the car, but should hold on to the column of the cab. Jumping is very likely to cause injury.**

In the following cases, the machine is very likely to tip over and must be avoided.

1) The machine is shifted on uneven ground, tracks are uneven, or more than half of one track is overhanging.

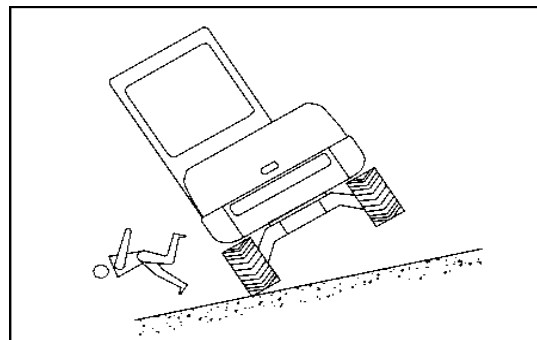

2) When the contact surface of one track is loose and the other is solid.

3) When there is a cavern or a mud pit under one side of the machine.

4) When traveling on a slope with a longitudinal slope greater than 25° and unloading heavy loads in the downhill direction.

5) When traveling on a slope with a transverse slope of more than 15° and unloading heavy loads in the downhill direction.

6) On a slope, the two tracks are 90° from the slope, and the platform swinging is greater than 90°.

7) When working on a slope, the machine makes a sharp turn, and the platform rotates rapidly or stops suddenly.

8) When the machine is swinging downward on the slope at 180°.

9) When doing the backward operation (trenching, etc.) and moves on to an uneven level.

- 10) When the machine is digging deep under the machine body.
- 11) When traveling on frozen ground.
- 12) When there is oil or lubricant on both tracks, the machine is prone to skid.

### 2.6.7. Transportation and Handling

- The transportation (loading and unloading) of the excavator must strictly observe the safety principles.
- When transporting the excavator, national and local industry rules or good practices for safe transport (loading and unloading) must be observed.

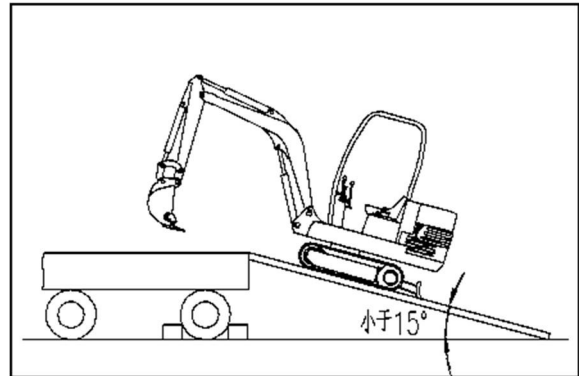

- When transporting the excavator, it is strictly forbidden to carry any person or other articles in the cab of the excavator.
- When transporting excavators, it is strictly forbidden to carry any personnel and other items in the cab of the excavator, and it is strictly forbidden to mix people and machines.
- When loading and unloading the excavator, It is strictly forbidden to have any personnel and articles that may hinder the loading and unloading within the radius of the crane boom (including the lifted object).
- When loading and unloading the excavator, there must not be any personnel and other articles that may hinder the loading and unloading within the traveling range of the excavator being loaded and unloaded (including the swing range of the excavator).
- In addition to the excavator being lifted or driven directly from the dock, the excavator can also be driven onto the transport vehicle using two hitching boards with sufficient strength. The angle of inclination of the hitch should be less than 15°, the length of the slope should be more than 3.5 times the height, and the width of the hitch should be about 1.2-1.5 times the width of the tracks.



- Before going up and down the slide, be sure to lock the swing lock of the rotary platform to prevent the platform from rotating.
- When going up and down the slide, do not maneuver any handle except the travel handle.
- Load and unload the machine on a firm and flat surface.
- Ensure that clearance flags, lights and WARNING signs are in place and visible to others when driving the machine on the roadway; ensure that the "slow moving vehicle" sign is visible to vehicles behind you.
- Tracked machines may damage road surfaces and have some restrictions when driving on them, so use a truck to transport the machine when required.

#### 2.6.8. Downtime maintenance



**WARNING: A "DO NOT OPERATE" sign must be attached to the control handle during any maintenance work on the machine.**

- The excavator must be stopped on a firm, level surface.
- Once the excavator is parked, the bucket must be lowered to the ground, the engine must be run at idle speed for three minutes, before shutting down the machine and removing the key.
- Release all hydraulic system pressure.
- When stopping on a slope as a last resort, provide adequate barriers in the downward direction of the tracks on both sides.
- Make sure to keep a certain distance from other machines when stopping.
- When repairing the electrical system or welding, remove the negative battery cable to prevent the battery from depleting.
- To work under the unit, make sure the support is strong and firm, do not work with only one jack.
- Do not lubricate or repair the machine when the engine is running, and do not allow hands, feet, or clothing to touch the power rotating parts.
- If maintenance is to be performed while the engine is running, the machine must

be guarded by a person.

- Do not carry loose items in your pockets to prevent them from falling into the moving parts.
- High-pressure liquids can hurt eyes or skin and should be handled with great care during maintenance.
- Remove all loose articles inside the machine to prevent malfunctions that could cause injury to personnel or damage to the machine.
- Dispose of waste fluids properly, do not pour oil into the ground, drains, creeks, ponds or lakes. When draining oil, fuel, antifreeze, plastic, battery and other hazardous waste, be sure to operate in compliance with environmental regulations.

### 2.6.9. Fire, Explosion and Poisoning Prevention

- Avoid touching the electric wire when the excavator is transporting, traveling and digging, otherwise it may lead to serious casualties.

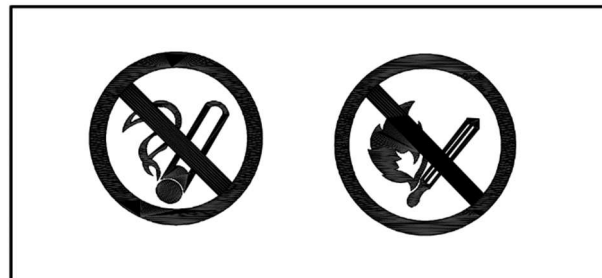

- Excavator electrical appliances and wiring should be checked frequently. If it is found to be banged up, damaged or aged, it must be replaced in time to prevent short circuit.

- Keep the wiring joints clean and firmly connected and check every day. Check whether the wire is loose or damaged, tighten the loose connector or wires.

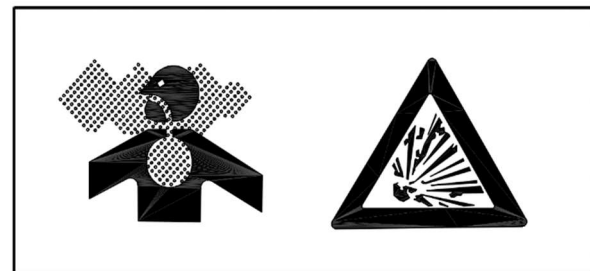

- Do not place flammable and explosive materials inside the excavator to prevent fire.
- When refueling, the engine must be stopped, keep fire away from the machine.

- Do not leave the machine unattended while refueling.
- The fuel must not spill onto overheated surfaces or the electrical parts.
- After refueling, wipe off any spilled fuel or oil and tighten the fuel and oil tank cap tightly.
- Remove any leaves, pieces of wood, paper and other flammable materials from the engine, exhaust pipe, muffler and engine compartment.
- No oil-soaked rags should be placed inside the machine to avoid spontaneous fire and combustion.
- Keep a fire extinguisher easily accessible in the cab.
- When welding the machine, it is strictly forbidden to do it without isolating the hydraulic oil line and fuel line.
- To prevent fires caused by hydraulic lines: Check that all hose and tube clamps, shields and cushions are securely fastened in place. If they are loose, they might vibrate and rub against other parts during operation, causing damage to the hoses and high pressure oil to spurt out, resulting in fire hazards or serious injuries.
- The battery should be kept away from the fire source and avoid high temperature, otherwise it may explode.
- User should check the seal of the isolation board to prevent engine exhaust gas from entering the cab.
- It is strictly forbidden to operate in poorly ventilated areas to prevent the driver from suffocation.
- In case of fire, do not use water to extinguish it, you should use powder fire extinguisher or use sand to press out the fire. Or you can use cover or tarp to put out the fire.

## 2.6.10. Battery

### ✧ General safety rules for batteries

The battery electrolyte contains sulfuric acid, which generates flammable and explosive hydrogen gas. Incorrect handling can lead to serious injury or fire, so the following precautions must be observed.

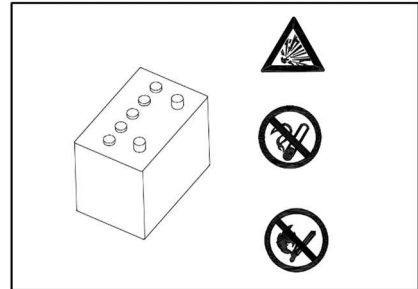

- When the indicator shows green, the battery is ready for use. When the indicator shows black, the battery should be charged in time, and when the indicator shows white, it should be replaced immediately.
- Wear safety glasses and rubber gloves when handling the battery.
- Do not smoke or use open flame near the battery.
- If eyes, clothing or skin are splashed with sulfuric acid, flush with plenty of water and seek medical attention immediately.
- Turn the key switch to the OFF position before handling the battery.
- Check the electrolyte level with a flashlight and turn off the engine when doing so.
- Expansion at the end of a sealed battery indicates that the battery has frozen. Do not charge the battery or jumper start the engine when the battery is frozen. Do not heat a frozen battery above 15°C, otherwise the battery may explode.

### ✧ Battery explosion prevention



#### **WARNING:**

**Electric spark or flame can make the hydrogen in the battery explode, to prevent the explosion, please Attention:**

- 1) **When disconnecting the battery cable, disconnect negative (-) cable first.**
- 2) **When connecting the battery cable, the negative (-) cable should be connected last.**

- 3) **The terminals of the battery cannot be shorted with metal parts.**
- 4) **Welding, grinding or smoking should not be done near the battery.**

Due to the risk of sparks, the following steps are to be followed.

- Firmly mount the battery.
- Do not allow tools or other metal objects to come in contact between the battery terminals. Do not place tools or other metal objects near the battery.
- Connect or disconnect the positive and negative terminals of the battery in the correct order. Battery terminals should be securely fastened.
- When charging the battery, flammable hydrogen gas is generated, so before charging, remove the battery from the lower body, put it in a well-ventilated place and remove the battery cover.
- Tighten the battery cover securely.

**ATTENTION: When repairing the electrical system or performing welding operations, remove the negative terminal of the battery to prevent the flow of current.**

### 2.6.11. Hydraulic system

#### A. Safety rules for high pressure oil

There is always pressure inside the hydraulic system. When inspecting or replacing a line or hose, always check that the pressure in the hydraulic line has been relieved. If the line is still under pressure, it can cause serious injury or damage.

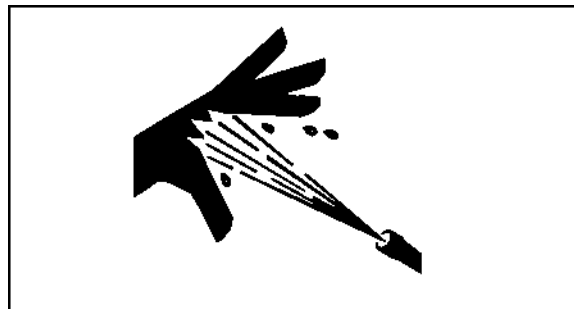

- 1) Do not inspect or replace the hydraulic system when there is pressure in it.
- 2) If there is any leakage in the line or hose and the surrounding area is wet, check the

line or hose for rupture and hose expansion. Wear goggles and leather gloves when doing so.

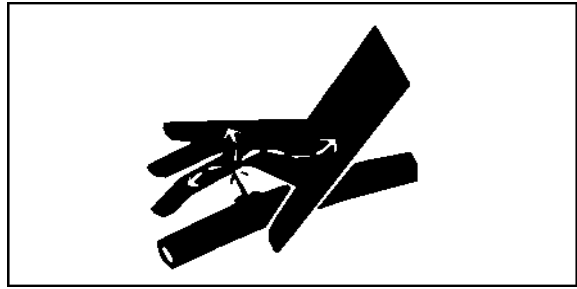

- 3) High-pressure oil leaking from a small hole can penetrate the skin and can cause blindness if it comes into direct contact with the eyes. If you are injured by a stream of high-pressure oil hitting your skin or eyes, flush with clean water and contact a doctor immediately for treatment.

### **B. Safe Handling of High Pressure Hoses**

If oil or fuel leaks from a high-pressure hose, it can cause a fire or malfunction in operation, resulting in serious injury or damage. If a loose bolt is found, stop work and tighten the bolt to the specified torque. Never weld the machine without isolating the hydraulic oil lines (hoses). If any damage is found to the hose, stop the operation immediately and contact your Yuchai dealer.

Replace the hose if the following problems are found.

- 1) Damaged or leaking hydraulic hose fittings.
- 2) Worn or broken cladding, or reinforcement wire exposed.
- 3) Swelling of the cladding in some places.
- 4) Twisted or crushed movable parts.
- 5) Impurities in the package.

### **C. Safety rules for high-temperature fluids**

Hydraulic oil that has not been cooled during or after operation is hot and high pressure. When checking or draining the oil, wait for the oil to cool until you can touch the cover before operate to prevent burns caused by the sprayed oil or by contact with hot parts. Even if the oil has cooled, slowly loosen the hydraulic tank air filter to drain the pressure inside the hydraulic tank before removing the cover.

#### D. Release the internal pressure of hydraulic system

Between machine operations, the hydraulic oil in the hydraulic lines is at high temperature and pressure. When the oil port is open, oil may spurt out, so rotate the oil filler cap to relieve the internal pressure before removing the cap.

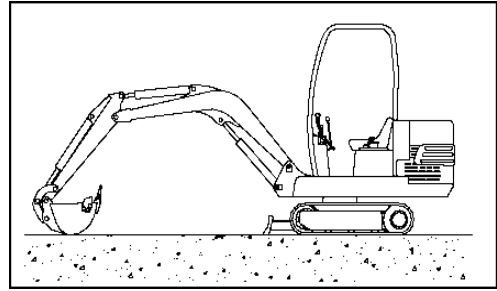

- 1) If the working device is not in the condition shown, start the engine at low speed, extend the bucket cylinder and retract the boom cylinder. Then drop the bucket to the ground, place the dozer on the ground, and turn off the engine.
- 2) Within 15 seconds of shutting down the engine, turn the start switch to the ON position and operate the lever in each direction (working device, travel, Swinging) to relieve internal pressure.

#### E. Safe operation of the accumulator



##### **WARNING:**

**The accumulator is a high-pressure nitrogen-filled component and improper use may cause an explosion or other hazard. The accumulator must not be disassembled, drilled, welded, etc. Keep the accumulator away from fire, and avoid impact and shock on the accumulator. When disposing of the accumulator, ask a professional to do so.**

The machine is equipped with an accumulator in the control line, which is a pressure storage device that allows the control line to be operated for a short time even after the engine is stopped.

By operating the joystick, the machine can be lowered under its own weight.

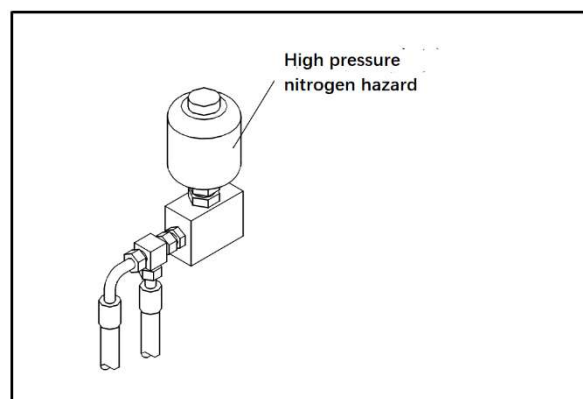

### **How to disassemble the pipes of a machine equipped with an accumulator**

- 1) Lower the machine to the ground and turn off the hydraulic hammer or other attachments.
- 2) Turn off the engine.
- 3) Turn the key of the starter switch to the ON position again to allow current to flow in the circuit.
- 4) Set the safety lockout control lever to the free position, then operate the levers and attachment control pedal forward, backward, left, and right at full stroke to release the pressure in control lines.
- 5) Set the safety lockout lever to the locked position to lock the joystick and attachment control pedal.



### 3. Introduction of Components

#### 3.1. Control Consoles

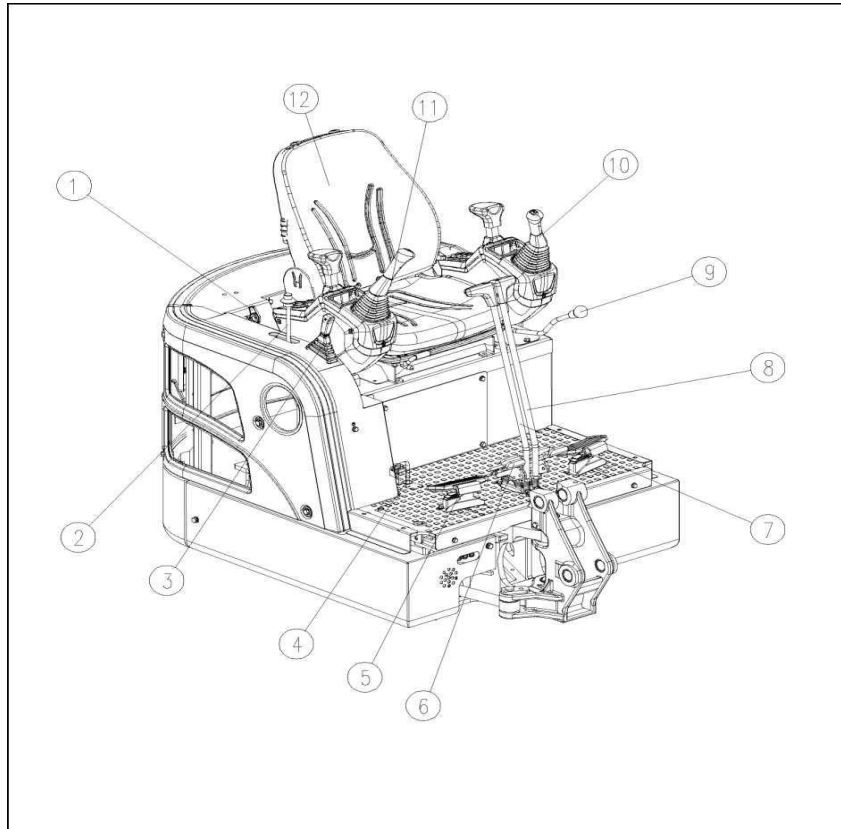

- |   |                   |   |                        |    |                       |
|---|-------------------|---|------------------------|----|-----------------------|
| 1 | Main power switch | 5 | Right attachment pedal | 9  | Left attachment pedal |
| 2 | Throttle          | 6 | Travel control pedal   | 10 | Pilot system lock     |
| 3 | Dozer lever       | 7 | Left travel pedal      | 11 | Left joystick         |
| 4 | Swing Lock        | 8 | Right travel pedal     | 12 | Right joystick        |
|   |                   |   |                        | 13 | Seat                  |

### 3.2. Safety locking components



#### **WARNING:**

**The working device safety locking mechanism is an important part of the safety system. The safety lockout must be engaged when the operator leaves the cab. If the joystick locking mechanism is not in the locked position, the handle may move and cause the working device to actuate, resulting in an accident.**

#### ● Pilot system locking and unlocking

Pull the pilot safety lock lever to top position and lift the left control box before start the ignition. In this condition, the pilot system control does not supply oil, the machine work device , platform Swinging, etc. cannot work (except for the left and right travel control).

After pushing the pilot safety locking handle forward and pressing it to the bottom and putting down the left operation box, the pilot system will be connected with the oil pressure source and the machine can work normally.

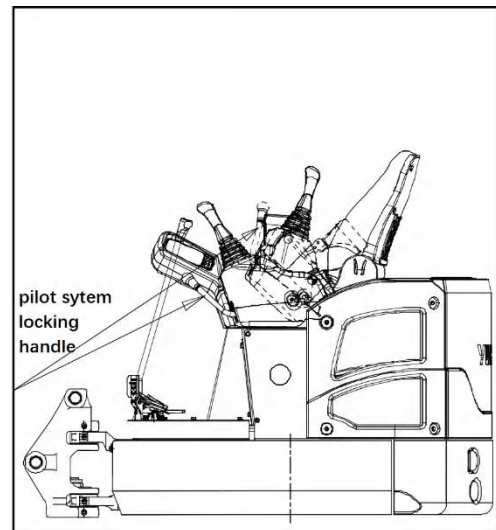

#### ● Platform locking mechanism (optional)



**WARNING: The platform locking mechanism is an important part of the machine safety system. When the machine is transported, traveling, parked or stopped on a ramp, the platform must be locked.**

#### **Platform locking and unlocking**

Lift the platform locking pin up, as shown in the figure, the pin on the bent plate a hangs at the lower box c, unlocking the platform from the bottom frame.

When the locking pin is lowered, the bent

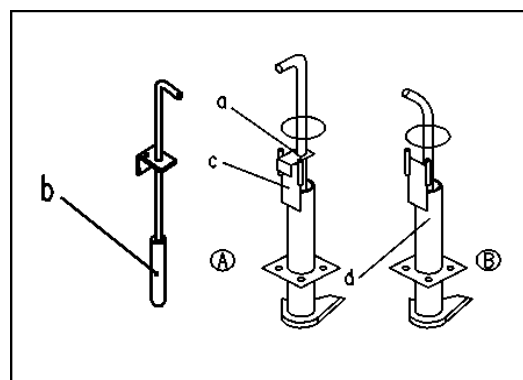
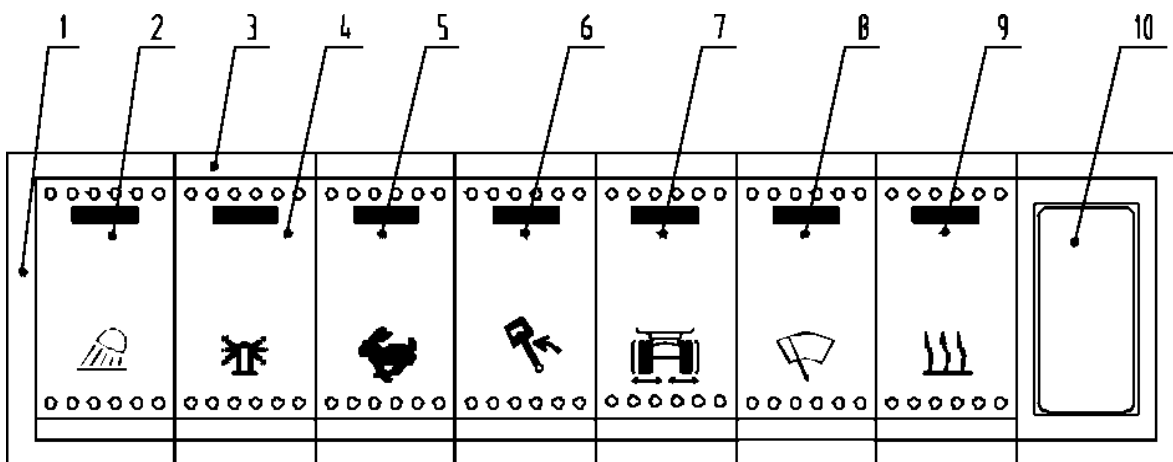

plate is placed at the lower box d, and the pin b locks the platform and the bottom frame.

When locking, make sure that the locking pin holes on the platform and the bottom frame must be aligned.

### 3.3. Switch assembly

Switch assembly of left control box - 1



**1) Out Frame**

**2) Working light switch**

Press the rocker switch, the side with the switch sign is on, and the other side is off.

**3) Middle Frame**

**4) Beacon switch**

Press the rocker switch, the side with the switch sign is on, and the other side is off

**5) Fast travel switch**

Press the toggle switch, the travel motor is in high speed and low torque travel state.

**6) Deflection switch (or on the pilot handle)**

Press the rocker switch and operate the left pilot handle to operate the deflector head to the left or right; press the rocker switch again to switch the deflector head back to

the default platform Swinging to the left or right.

#### 7) Chassis telescopic switch

Press the rocker switch, the dozing handle switches to the chassis telescopic state.

#### 8) wiper switch

Press the wiper switch, the wiper is working.

#### 9) Heater

Press the air heater switch, the air heater is working.

#### 10) Cover plate

### 3.4. Electronics Controls

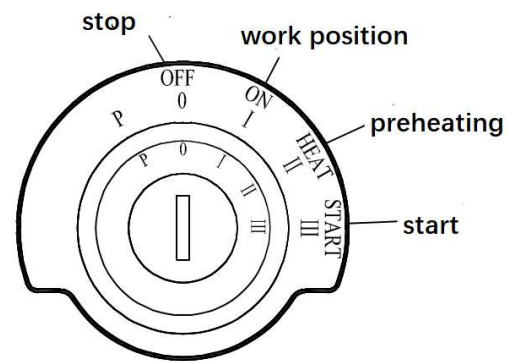

Ignition switch

#### 3.4.1. Key (start switch operation)

**Stop** : the electrical system is off.

**Work position-ON** : the electrical system is on.

**Preheating**: the engine starts to preheat and intake air; at this time, the preheating indicator light is on. It should be ATTENTIONd that the warm-up time should not exceed 30 seconds. This position can be automatically reset.

**Start**: The engine starter motor starts to run.

### 3.4.2. Cigarette lighter

## 3.5. Monitor

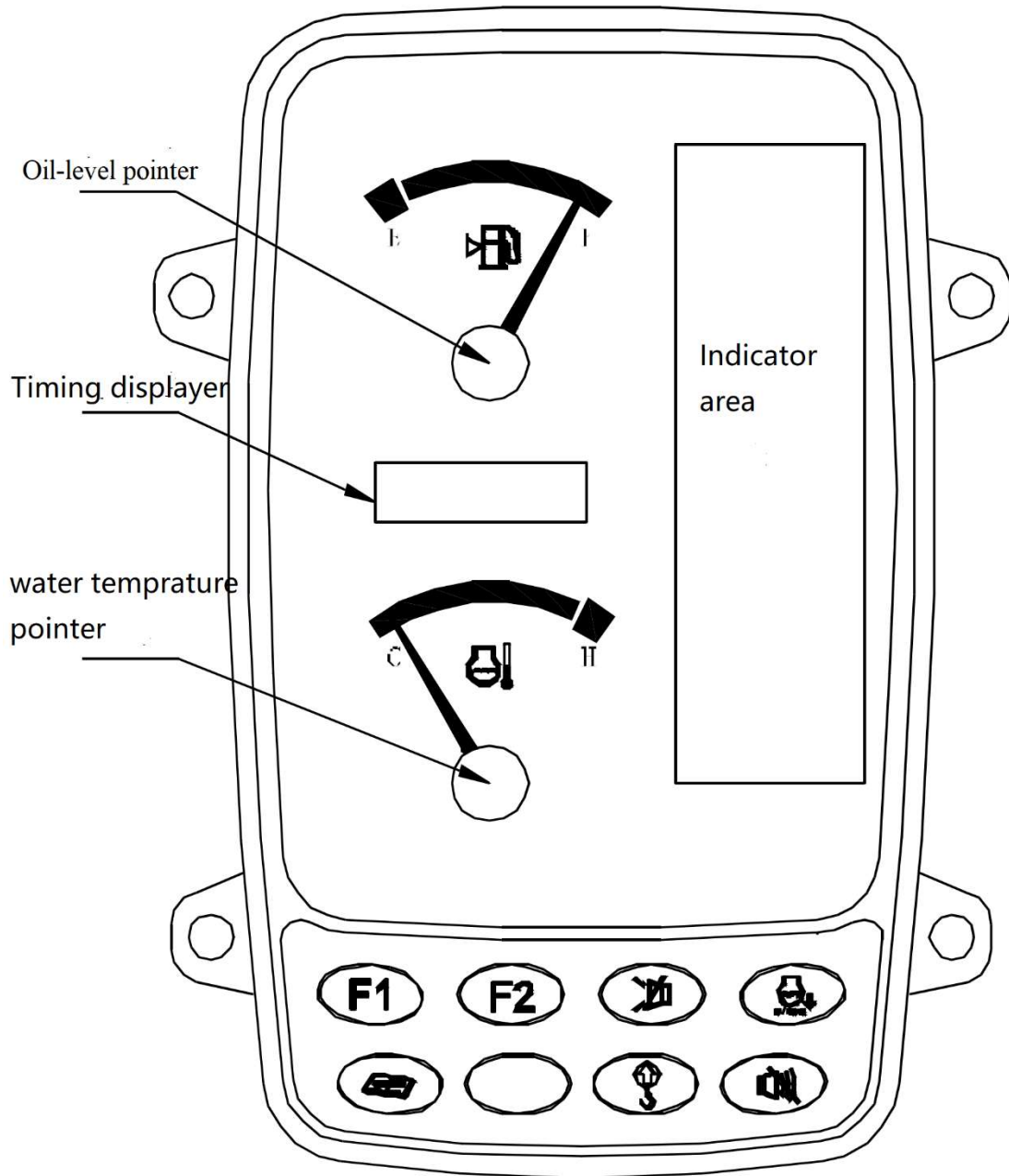

### 3.6. Work device s and Swing Controls

- Control of excavation work device and platform Swinging

#### A) Left joystick

**Arm** extends out when pushing up, and retracts in when pulling back.

**Platform slewing:** platform turns right when joystick moves right, platform turns left when joystick moves left.

**Offset boom:** boom swinging right when joystick moves right, boom swinging left when joystick moves left.

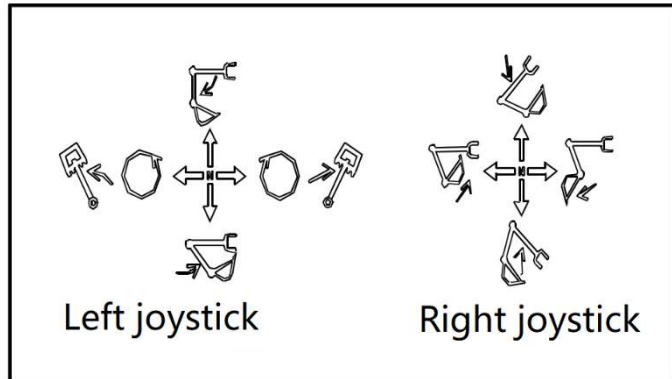

#### B) Right joystick

**Boom** is lowered when pushing forward and retracted when pulling back.

**Bucket:** bucket is turned outward when joystick turn right, and turned inward when joystick turn left.

- slewing or offset boom function selection ( joystick button switch)

Both slewing and offset boom function are operated by right joystick.

Default setting is slewing action.

Press button 1 to execute the offset boom function.

Press key 2 to reset and execute the default Slewing function.

**ATTENTION: If the selection switch is mounted on right control box, there is no such setting on the right joystick.**

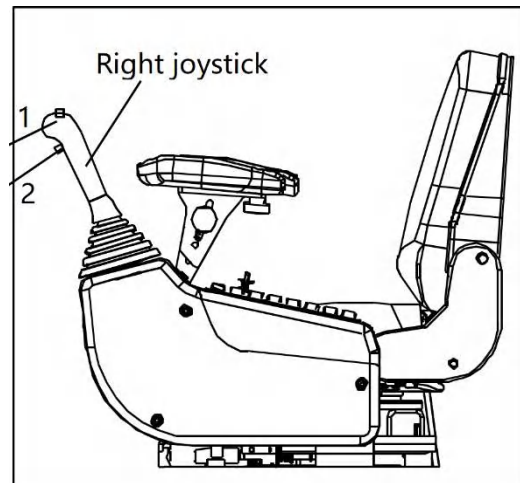

- **Operation of the dozer**

Push the lever down to push the dozer plate downwards. When pulling up, the dozer plate is lifted.

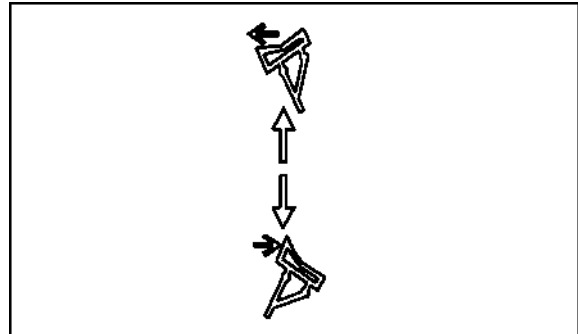

- **Operation of the auxiliary work device**

When the machine is equipped with an auxiliary work device , the auxiliary oil supply is switched on by pressing the foot pedal of the auxiliary work device .

### 3.7. Travel control

- **Directional control**

The left and right travel levers control the left and right tracks of the machine.

Maneuver single lever can control one side of the track to turn the machine.

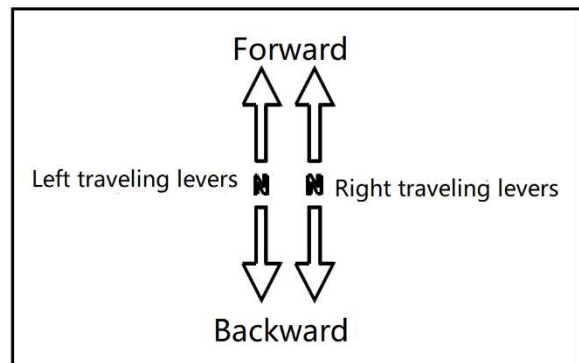

### 3.8. Throttle handle and stop handle

#### 1) Throttle Handle

Push the engine throttle handle forward to increase the throttle. Before the engine stops, pull the throttle handle back to the head.

#### 2) Stop Handle

Before the engine is turned off, pull the stop handle back to the end.

After the engine is turned off, push the stop handle forward to the end.

### 3.9. Driver's Seat



**WARNING: Accidental tilting or sudden movement of the machine may result in injury or even death. Therefore, for safety reasons, remember to fasten the seat belt and adjust the seat before starting the machine.**

Seat forward-backward adjust handle ①

**Seat forward-backward adjust:** push the handle the adjust

**ATTENTION:** Stop operating the machine before adjusting seat. And shake the seat lightly after adjustment to confirm the seat is secured.

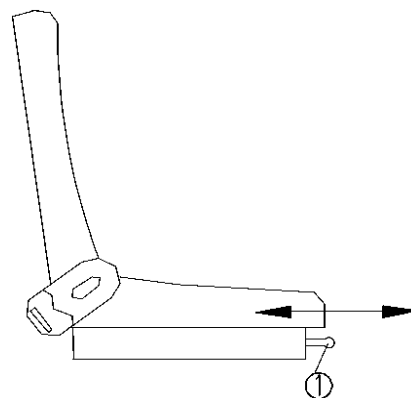

### 3.10. Seat belt



**WARNING: The seat belt is an important part of the safety system. The seat belt must be fastened before operation. If the seat belt is not fastened, the cab or machine may crush your body and cause injury if the machine tips over.**



**WARNING: Before using the seat belt, check the installation of the seat belt for any abnormalities. If the seat belt is worn or damaged, replace it.**

- **Replace the seat belt every 3 years even if you do not see any abnormalities. The date of manufacture of the harness is shown on the factory date label of the harness.**
- **Always wear your seat belt during operation.**
- **Do not twist the seat belt when wearing it.**

- 1) Secure the seat belt



Hold the harness clip, check that it is not twisted, adjust the length of the harness and insert it firmly into the buckle. Gently pull the seat belt and check that it is properly locked.

2) Remove the seat belt

Press the red button on the buckle and remove the clip from the buckle to remove the seat belt.

## 4. Operation Instructions

### 4.1. Preparation before operating the machine

- 1) The excavator should be operated by a trained driver . The machine should meet the specific requirements of each region for the driver to operate independently.
- 2) The driver is strictly forbidden to operate the machine until he/she is familiar with the instruction manual.
- 3) The driver must put on tight fitting clothes and relevant safety protection items such as helmet, leather shoes, gloves, protective glasses, safety belt, etc. before operation.
- 4) Check the machine carefully before starting
- 5) Check the working device, oil cylinder and hose for damage.
- 6) Clear the dust and dirt around the engine, radiator and battery.
- 7) Check whether the hydraulic device, oil tank, hoses and joints are leaking oil (you can check whether there are obvious oil stains on the parking ground).
- 8) Check whether the lower frame parts (tracks, drive wheels, guide wheels, etc.) are damaged and whether the bolts are loose. The frame and platform bolts are not loosened.
- 9) Check that the instruments and monitors are not damaged.
- 10) Clean the rear view mirror, check if it is damaged, and adjust the angle so that you can see the correct view.
- 11) Check the seat belt for damage.
- 12) Make sure that the correct maintenance has been carried out in accordance with the specified requirements.



**WARNING: Before operating the machine, make sure that you understand and are familiar with the safety instructions in this manual "Safety Instructions" regarding the safe operation of the machine.**

## 4.2. Engine Operation



**WARNING: Before starting the engine, review the safety instructions in this manual. Read all safety signs on the machine. No other people are allowed in the workplace. Before operating, learn and practice safe operation. When operating the machine, you must be clear of and follow the operation and maintenance requirements in the manual.**

### 4.2.1. Check before starting the engine

- 1) Check that the seat belt is fastened, sound the horn, and make sure that there are no people around the work area or near the machine.
- 2) Check that all windows and mirrors for good view.
- 3) Check whether there is dust or dirt around the engine, battery and radiator, and remove them if there is.
- 4) Check that there are no cracks, excessive wear or gap in the working device, oil cylinder, connecting rod, hydraulic hose. If abnormalities are found, replace and repair.
- 5) Check whether the hydraulic device, hydraulic oil tank, hose and joint are leaking oil.
- 6) Check the lower body (tracks, sprockets, guide wheels, etc.) for damage, wear, loose bolts or oil leaks.
- 7) Check whether the instrument display is normal, whether the working lights can work normally, and whether the electrical circuit is broken or disconnected.
- 8) Check the coolant level, fuel oil level, hydraulic oil level and engine oil level
- 9) Check whether the coolant, fuel, hydraulic oil, battery electrolyte, oil and lubricating oil are frozen in cold weather, and thaw the engine before use if it is frozen
- 10) Check whether the platform is in the locked state.
- 11) Check the working condition, direction and position of the machine in order to

provide relevant information for operation.

#### 4.2.2. Starting the engine



**WARNING: Starting the engine is not allowed when there is a “no engine start” WARNING sign on the joystick.**



**WARNING: Before starting the engine, make sure the safety locking handle is in the locked position to prevent accidental maneuver of the lever during start-up, which could cause the working device to move abruptly and cause an accident.**



**WARNING: When starting the engine in cold weather, it must be preheated. If the machine is not thoroughly warmed up before operating the joystick, the machine could be unresponsive and this could lead to an accident.**



**WARNING: If the battery electrolyte freezes, do not charge the battery or start the engine with alternative power source. Doing so will put the battery at risk of catching fire. Before charging or starting the engine with alternative power source, allow the battery electrolyte to thaw and check the battery electrolyte for freezing and leaks before starting.**

Before starting the engine, insert the key into the starter switch and turn it to the ON position, check the status of all indicator lights on the monitor.

##### **A) Starting engine in normal temperature**

When the ambient temperature is over 5 degrees, turn the key clockwise to the ON running position, the alarm light goes off to indicate that the machine can be started normally, continue to turn to the START position and hold it in this position for no more than 15 seconds. After the engine is started, release the

key and it will automatically return to the ON position. If the engine does not start. Try again after 30 seconds.

#### **B) Starting the engine in cold temperatures**

When the ambient temperature is below 5 degrees, the engine must be warmed up by turning the key counterclockwise to the HEAT position. After about 6 seconds, the preheat indicator light will go out, then turn the key clockwise to START position to start the engine.

**ATTENTION: The warm-up time should not exceed 30 seconds.**

**ATTENTION: Continuous starting time should not exceed 15 seconds; the interval between two starts should not be less than 30 seconds; if the engine cannot be started three times in a row, check whether the engine systems are normal.**

#### **WARNING:**



- 1) **Do not turn the key while the engine is running. It will damage the engine.**
- 2) **Do not start the engine while towing the excavator.**
- 3) **Do not start the engine by short-circuiting the starter motor circuit.**

#### **4.2.2.1. Starting the engine with the jumper cable**



**WARNING: When the battery electrolyte is frozen, the battery will explode if (1) you try to charge it, or (2) start the engine with jumper cable. To prevent the battery electrolyte from freezing, keep it fully charged. If these instructions are not followed, you or someone else may be injured.**



**WARNING: The battery can generate explosive gas. Keep it away from**

**sparks, flames and fireworks. When charging or using the battery in a confined area, maintain ventilation and wear eye protection when working near the battery.**

If the jumper cable is connected in a wrong way, it can cause the battery to explode. Therefore, follow the rules below.

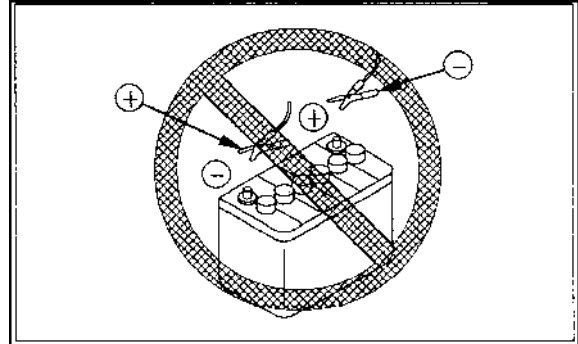

- 1) When starting with the jumper cable, two people should start the machine (one person in the operator's seat and the other person operating the battery).
- 2) When starting with another machine, keep them with a safe distance
- 3) When connecting the jumper cable, turn the key switch of the normal machine and the defective machine to the OFF position. Otherwise, there is a danger of the machine moves when the power is turned on.

- 4) When installing the jumper cable, be sure to first connect the positive (+); when removing the auxiliary cable, you should first disconnect the ground or negative (-) cable.

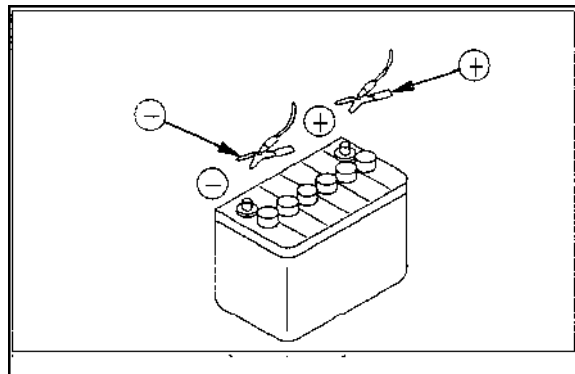

- 5) When removing the jumper cable, be careful not to let the jumper cable clamps touch each other or let the cable clamps come in contact with the machine.
- 6) Always wear eye protection and rubber gloves when starting the engine with the jumper cable.
- 7) Make sure the 2 machine use same power voltage.

#### 4.2.3. After starting the engine

##### A) Engine warm-up and machine warm-up

The normal operating temperature of hydraulic oil is 50°C~80°C. Operation with hydraulic oil below 20°C will damage the hydraulic components. Therefore, if the oil temperature is below 20°C, the following warm-up procedure must be followed before starting operation.

- 1) The engine runs at 200rpm speed for 5min
- 2) The engine throttle is placed in the middle position for 5~10min
- 3) At this speed, extend and retract each cylinder several times and gently operate the rotary and travel motors to warm them up. When the oil temperature reaches 20°C or above, operator can start work. If necessary, extend or retract the bucket cylinder to the end of its stroke to warm up the hydraulic oil at full load, but not more than 30 seconds at a time. Repeat until the oil temperature requirement is reached.

##### B) Check after starting the engine

- 1) Check if the indicator lights are off.
- 2) Check oil (lubricating oil, fuel) and water leaks.
- 3) Check the sound, vibration, heating, smell and instruments of the machine for any abnormalities. If any abnormalities are found, repair immediately.

#### 4.2.4. Shut down the engine

**ATTENTION: If the engine is suddenly shut down before it cools down, it will greatly shorten the engine life. Therefore, do not turn off the engine abruptly except in an emergency.**

**If the engine is overheated, do not shut it down suddenly, but run it at idle speed to cool it down gradually, and then shut it down.**

- 1) Run the engine at low idle speed for about 5 minutes to allow it to cool down gradually.

- 2) Push the throttle forward to the end and pull the stop handle back to the end.
- 3) Turn the key switch to OFF position and turn off the engine. Each indicator light goes off.
- 4) Remove the starter switch key.
- 5) Push the stop handle forward to the end after the engine is stopped.

#### 4.2.5. Check after turning off the engine

- 1) Inspect the working device, appearance of the machine and chassis. Check for water or oil leaks. If abnormalities are found, repair them.
- 2) Fill the fuel tank.
- 3) Check the engine room for foreign articles. Remove confetti and debris to avoid fire.
- 4) Remove the mud on the chassis.

### 4.3. Enter and exit the machine

- 1) Make sure your hands are firmly on the handrail at the cab door.
- 2) Step firmly on the tracks.
- 3) When getting on and off the machine, do not use the control handle as a handrail to grip.
- 4) Before getting on or off the machine, make sure that there is no mud, grease or other substances on the surface on the handrails and tracks that may cause slippage.
- 5) Do not jump on or off the machine, and do not get on or off the machine while it is in motion.
- 6) Before exiting the machine, lower the work device completely to the ground and turn off the engine.

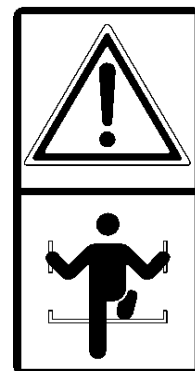
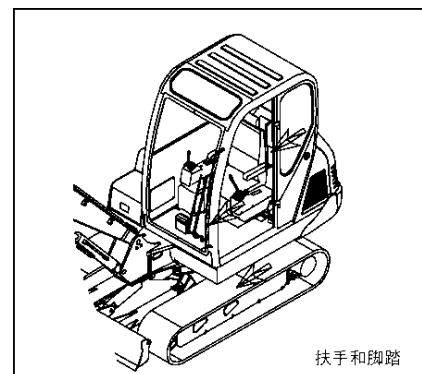



Then use the joystick safety handle to pull up the left control box in a locked position and keep it in this position until the next time the machine is operated.

**ATTENTION: When leaving, remove the key and lock all doors and windows.**

**Do not climb on top of the fuel tank, engine hood or cab.**

**Do not allow people to be on the work equipment (bucket, boom, boom and attachments) in any condition.**

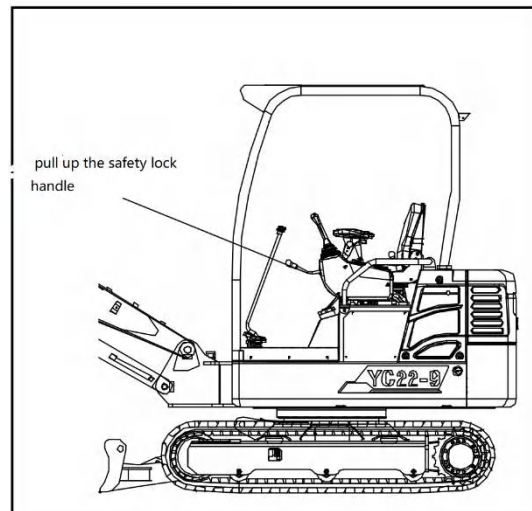

## 4.4. Traveling

### 4.4.1. Safety principles for traveling

- 1) Before starting the excavator, check the surroundings of the site for pedestrians and obstacles, ground bearing capacity, etc.
- 2) Sound the horn before starting the excavator.
- 3) It is strictly forbidden to start and operate the machine with the driver not in the cab.
- 4) The excavator must travel and operate on solid ground with a width of more than 1.5 times of that of the machine.
- 5) When traveling through underground passages, bridges or under high-voltage power lines, ensure that there is signalman to command.
- 6) When traveling, the arm and boom must be lowered to maintain the best position of the center of gravity.
- 7) When traveling, only the driver is allowed to drive on the machine.
- 8) When traveling on a flat road for a long distance, the platform can be unlocked, but the platform must be locked when traveling up and down the slope. Before

operating the steering lever, check the direction of the chassis.

- 9) If the dozer facing backward, the control of the travel joystick is reversed.
- 10) Do not allow anyone to be in the area around the machine.
- 11) Remove all obstacles from the machine's travel path.
- 12) The rear of the machine is a blind area, so pay special attention when traveling in reverse.



**WARNING: Sudden maneuver of the joystick in any direction when traveling at high speed can be dangerous.**

- 1) **Do not switch the joystick suddenly, otherwise it will cause sudden start.**
- 2) **Avoid abruptly changing the joystick from forward to reverse (or from reverse to forward).**
- 3) **Avoid sudden switching of the joystick, such as a sudden stop from high speed (or release the joystick).**

#### 4.4.2. Preparation for traveling

- 1) Put down the platform locking pin to lock the platform.
- 2) Turn the throttle handle to the high speed position to increase the engine speed.

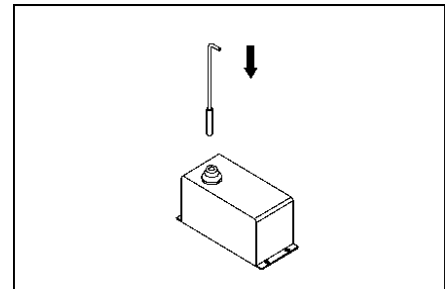

#### 4.4.3. Travel forward

- 1) Lower the left control box, raise the working device and lift it off the ground by 40 to 50cm

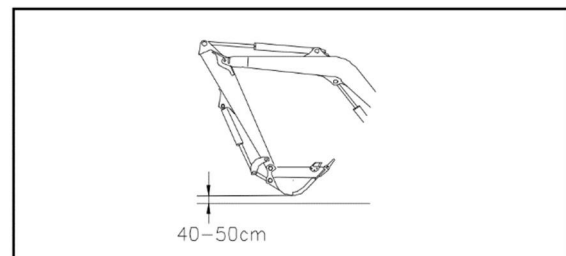

2) Maneuver both travel levers as follows.

When the dozer is facing front, slowly push both lever forward to control the machine travel.

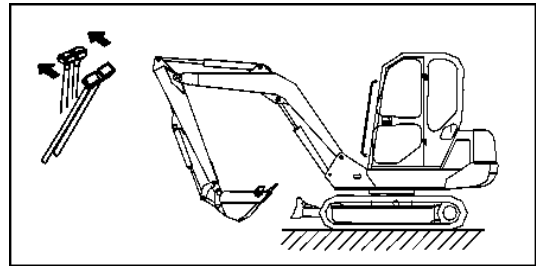

When the dozer is facing rear ,slowly pull both lever backward to control the machine travel.

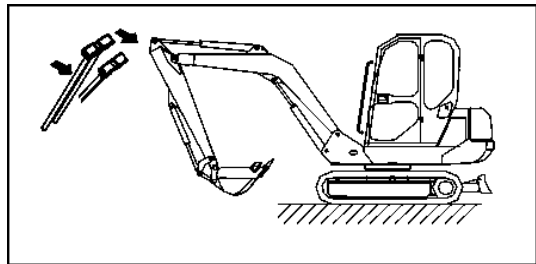

**ATTENTION: In low temperatures, the machine's travel speed could be abnormal, when the machine is not warmed up thoroughly. Also, if the chassis is clogged with dirt and the machine is not running properly, remove the dirt and mud.**

#### 4.4.4. Travel backward

- 1) Lower the left control box, raise the working device and lift it 40 to 50cm off the ground.
- 2) Operate in the opposite way to forward.

#### 4.4.5. Stop the machine

Put both levers in the middle position to stop the machine.

**ATTENTION: Avoid stopping the machine suddenly when it is traveling.**

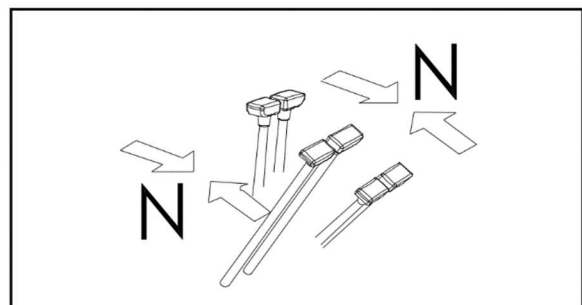

## 4.5. Steering

**ATTENTION: Before operating the travel lever, check the position of the dozer. If the dozer is facing back ward, operate the travel lever in the reversed direction.**

Use the left and right travel joysticks to change the direction of travel.

Avoid sudden changes of direction if possible. In particular, when making a spin turn, stop the machine before turning.

### 4.5.1. Turning when the machine is stopped

When turning to the left.

When traveling forward, push the right traveling lever forward and turn the machine to the left. When traveling backward, pull back the right travel lever and turn the machine to the left.

When turning to the right, operate the left travel lever in the same way.

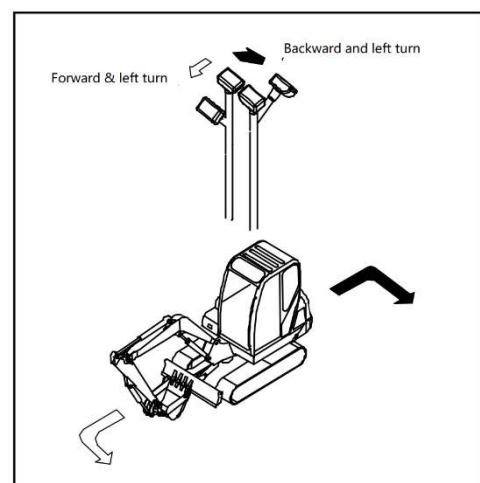

### Spin turn

When turning left in place, pull the left travel lever back and push the right travel lever forward.

When making a right turn in place, pull back the right travel lever and push forward the left travel lever.

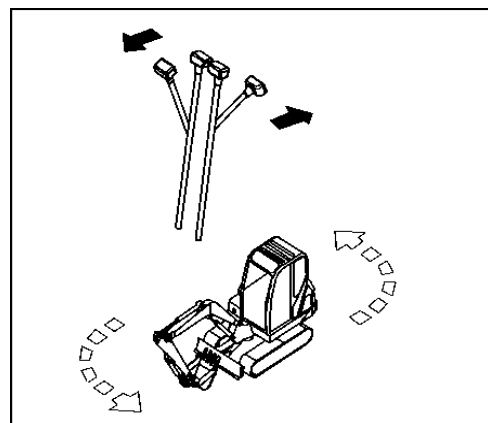

## 4.6. Rotation

- Before rotating the upper, check that the surrounding area is safe.
- Make sure that the platform is unlocked from the chassis by lifting the platform locking pin.
- The rotating speed is proportionate to the maneuver spin of the left joystick.

- 1) Lift the platform locking pin to unlock the platform from the chassis before slewing
- 2) Disconnect the deflection switch.
- 3) Maneuver the left joystick to rotating.
- 4) Engage swing lock when not rotating.

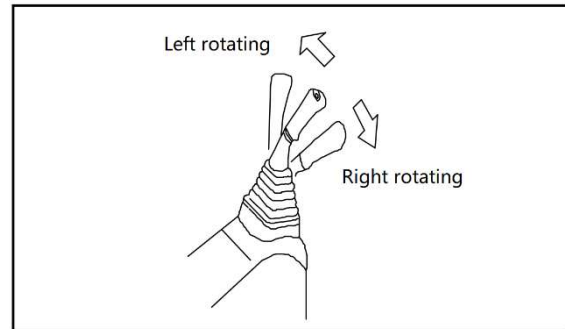

## 4.7. Working device Operations

The working device operate speed is proportionate to the maneuver spin of the joystick.

The working device is operated by the left and right joysticks. The left joystick operates the boom and swing (if equipped with a boom deflection selection switch, the left joystick can also control deflection). The right joystick operates the arm and bucket.

When the joystick or dozer lever is released, they automatically return to the neutral position and the working device or dozer stops.

If the joystick is operated within 15 seconds after shutting off the engine, the working device can still be dropped to the ground.

It is possible to operate the joystick to release the remaining pressure in the hydraulic line and to drop the arm after the machine is loaded on the trailer.

### 4.7.1. Arm control

The left joystick:

Forward-→arm is extended;

Backward-→arm is retracted

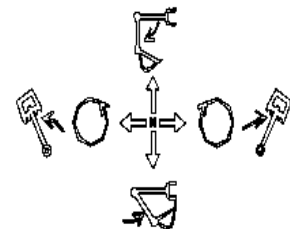

#### 4.7.2. Rotation control

Select the rotation mode on the left joystick first.

Operate the left joystick to rotate the platform.

Before rotating, it is necessary to make sure that the machine is in a rotation mode.

#### 4.7.3. Boom control

The right joystick

Forward-→boom is lowered.

Backward-→boom is raised.

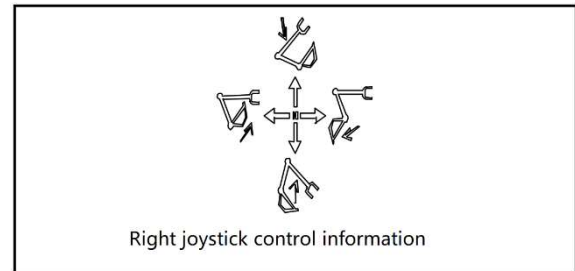

#### 4.7.4. Bucket control

The right joystick – maneuver to the right to rotate out the bucket, and to left to rotate it in.

#### 4.7.5. Boom deflection control

Select the deflect mode on the joystick first.

Operate the left joystick to deflect the boom.

#### 4.7.6. Dozer blade control

Dozer blade lever – push down to turn dozer downward and pull up to lift the dozer up.

**Attention: Arm control may lag, this is not a mechanical problem. Because when the stick moves, the self weight makes the arm move faster, which may cause insufficient oil supply.**

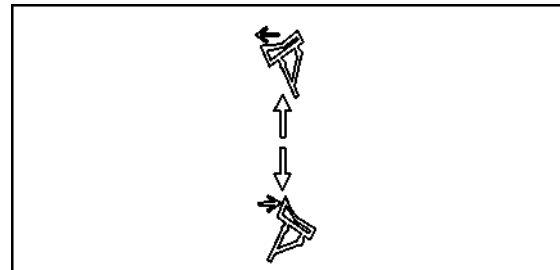

## 4.8. Working on slope or water



**WARNING: Working near slopes in the foothills is very dangerous. Rain, mud, snow, ice, loose sand, and soft ground pose potential hazards. Make sure it is completely safe before operate.**

### 4.8.1. Slope

- When traveling, raise the bucket about 20~30cm off the ground.
- Do not travel backwards downhill.
- When traveling over obstacle, keep the working device close to the ground and travel slowly.
- Do not turn or go side ways on the slope. You can go to a flat place to turn beforehand.
- When working on a slope, turning or operating the working device can cause the machine to lose balance and tip over, so avoid doing so.
- When the bucket is loaded, it is very dangerous to turn in the downhill direction, so build a platform on the slope with soil so that the machine can be balanced during operation.
- Do not go up or down steep slopes, as there is a risk of the machine tipping over.
- When traveling uphill, if the track plate slips, do not use working devices to help the machine go up the slope, as there is a danger of the machine tipping over.
- Make sure that the engine and hydraulic oil are properly warmed up when traveling up a slope, otherwise it may cause an accident.

### Permissible water depth

Do not drive the machine in water deeper than the midline of the pallets.

Grease parts that have been submerged for a long time until the grease is squeezed out of the zerks.

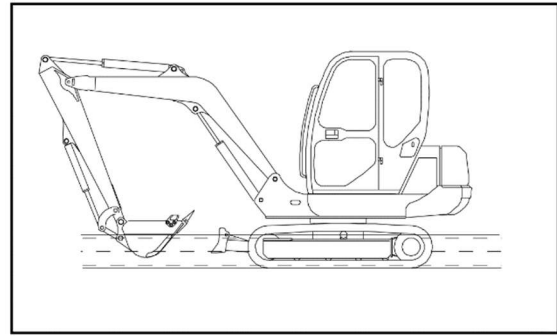

## 4.9. Getting out of the Muddy Environment

Always operate carefully to avoid getting stuck in the mud. If the machine gets stuck in the mud, follow the steps below to get the machine out.

### A) One side of the tracks is stuck

**ATTENTION: When lifting the machine with working device, be sure to keep the bottom of the bucket in contact with the ground. (Do not use bucket teeth to push). The angle between the arm and boom should be 90 to 110 degrees.**

When only one side of the track is stuck in the mud, lift the track with the bucket, then put a board or log under it and drive the machine out. If necessary, put boards under the bucket as well.

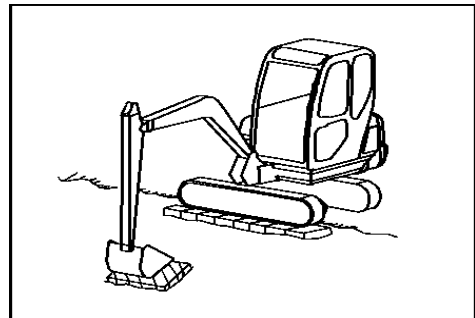

### B) Both tracks are stuck

If both tracks are stuck in the mud and are slipping. Place boards or logs under both tracks using the method provided above.

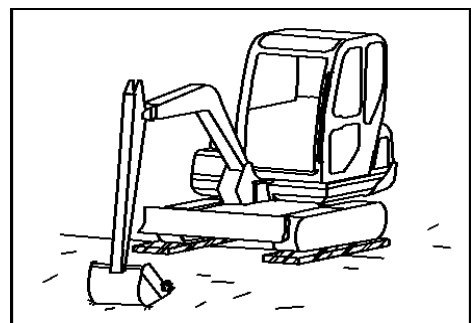



## 4.10. General Operations instruction

### 4.10.1. Backhoe operation

The backhoe is suitable for digging below the machine.

Maximum bucket thrust is achieved when the machine is in the position shown in the diagram to the right, i.e., when the bucket cylinder is at  $90^\circ$  to the connecting rod and the boom cylinder is at  $90^\circ$  to the boom.

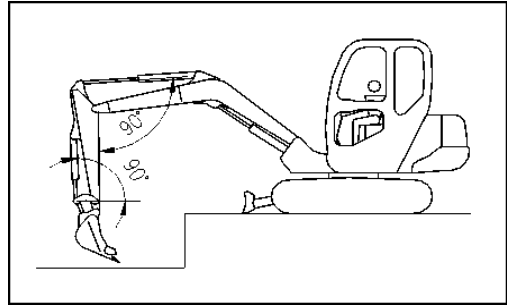

The digging range of the boom is from an angle of  $45^\circ$  away from the machine to an angle of  $30^\circ$  toward the machine.

This may vary depending on the digging depth, but try to operate within this range rather than operating the cylinder to the end of its stroke.

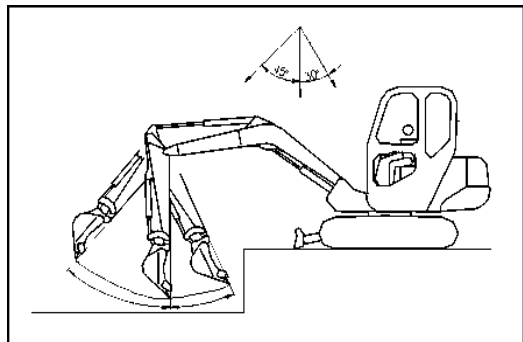

**ATTENTION: It is best to excavate hard rocky ground after it has been smashed by other means. This will not only reduce the damage to the machine, but is also more economical.**

### 4.10.2. Loading operation

It is more efficient to park the dump truck in a place where the operator can easily see it at a low slew angle.

It is easier and more convenient to load from the rear of the dump truck than from the side of the dump truck.

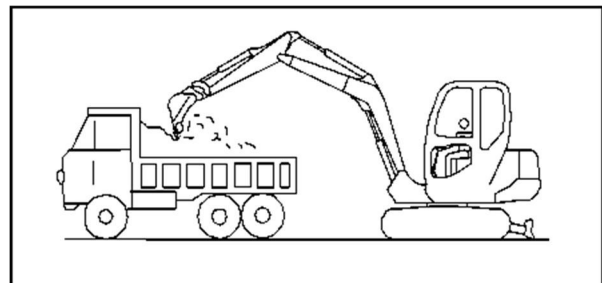

#### 4.10.3. Trenching operations

Keep the dozer at the rear and anchor it into the soil surface.

Extend the arm and boom and insert the bucket teeth into the soil surface.

Use the boom cylinder to dig. During the digging process, adjust the cutting and loading angle of the bucket at the right time, or switch to digging with the bucket cylinder. When digging, do not insert the bucket teeth too deep into the soil to avoid overloading the hydraulic system. If soil resist stops the bucket, lift the arm appropriately and continue digging. When the bucket is full, lift the arm and boom to raise the bucket above the ground and turn the platform to the proper position to unload.

#### **Attention.**

1) **Do not touch power lines in the air.**

2) **Check the under ground utility lines or pipe lines before digging.**

3) **In case of electric shock accident, the driver should not leave the seat and warn others not to approach. Drive the machine to a safe place and leave the cab after power off.**

#### 4.10.4. Backfilling or grading

In order to fill the ditch, the direction of excavator travel should be perpendicular to the ditch, dig the dozer into the soil, release the dozer lever. Start the machine and push the soil in the ditch with the dozer.

#### 4.10.5. Shake off the soil stuck in the bucket

Raise the boom to about horizontal, rotate the bucket to unloading position. Repeat the rotation several times to shake the soil off. Do not shock the bucket by extending the bucket cylinder to the end of the stroke.

#### 4.10.6. Precautions for the use of related parts

A) **Precautions for the use of tracks**

- 1) Excessive debris entering the tracks might cause the tracks to over load, damaging the track motors.
- 2) Avoid making sudden turns on road with strong friction.
- 3) Avoid contacting salt water or gas as much as possible.
- 4) If the tracks are not used for a long period of time, keep them in a cool and dry place.
- 5) When one track and the front unit are jacked up, do not travel on the other track as this will cause wear and tear.
- 6) The tracks must not be slack when traveling, otherwise the tracks may fall off or be damaged.

#### **B) Precautions when using the dozer**

- 1) The dozer should only be used for moving soil, not for digging, as this may damage the dozer or the track system.
- 2) The dozer cant carry heavy objects that is too big or unstable center of gravity, otherwise the dozer or the tracks will be damaged.
- 3) The dozer must not hook on any object while traveling, otherwise it will damage the dozer or the track system.
- 4) When lifting the machine with the bucket, make sure the road surface is level and the bucket is firmly in contact with the ground.

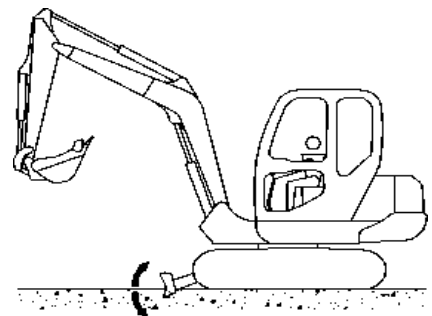

### **4.11. Removal and installation of bucket**

#### **A) Safety principles**

- 1) When striking pin with a hammer, metal chips may fly into the eyes and cause serious injury. Always wear goggles, helmet, gloves and other protective equipment when

performing this operation.

- 2) When removing the bucket, keep the bucket in a stable position.
- 3) If the pin is struck too hard, the pin may fly out and injure people in the surrounding area. Therefore, make sure the surrounding area is safe before striking the pin.
- 4) When removing the pin, take special care not to stand under the bucket or place your feet or any part of your body under the bucket.
- 5) When removing or installing pins, be careful not to bruise your hands.
- 6) When aligning the holes, do not put your fingers into the pins.

## B) Installation

Park the machine on a firm, level surface. Make sure the operator can communicate with other workers clearly.

Start the excavator and face the bucket, manipulate the arm until the hole between the arm and the bucket is aligned. Insert a steel rod with diameter 30 mm into the hole 1.

Lift the boom and arm so that the bucket hangs vertically.

Operate the arm cylinder so that the hole in the connecting rod is aligned with the hole in the bucket. Install the shaft 2, remove the rod 1 and install the shaft 3.

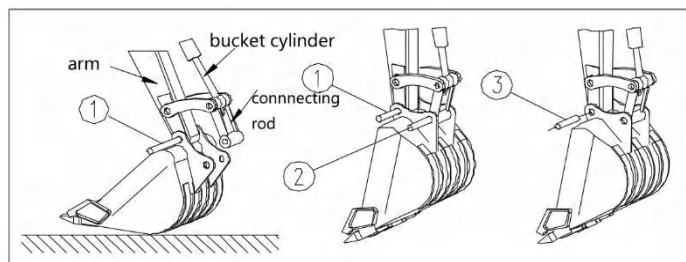

## 4.12. Disassembly

Park the machine on firm, level surface. It is necessary to place the bucket in a position where it is just in contact with the ground. If the bucket is firmly placed on the ground, it will increase the resistance and it will not be easy to remove the pin.

Remove the double nuts from the locking bolts of each pin of the arm and connecting rod, remove the bolts, then remove the arm pin (3) and connecting rod pin (2) and remove the bucket.

## 4.13.Parking

- **Safety principles**

- 1) Avoid sudden stops. Always park in open space.
- 2) Park the machine on a firm and level surface. Avoid parking the machine on a slope. If the machine must be parked on a slope, put a pad under the tracks and insert the bucket into the ground to prevent the machine from moving.

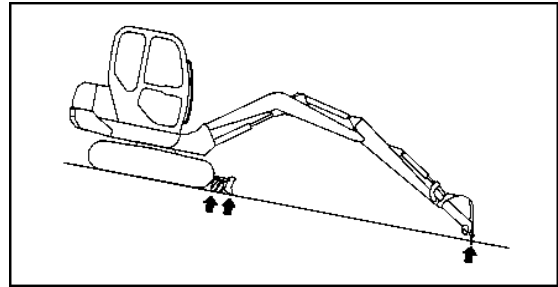

- 3) If you accidentally touch the left and right joysticks or the left and right travel levers, the work device or machine can move suddenly and cause serious injury or accident. Therefore, before standing up from the seat, always lift up the left control box and keep the machine in a locked position.

- **Parking the machine**

- 1) Place the left and right travel levers in the neutral position. Stop the machine.
- 2) When the engine is working under heavy load, do not stop immediately, let it run at low speed for 1-2 minutes to clear overheating before stopping.
- 3) Drop the bucket and dozer to the ground.

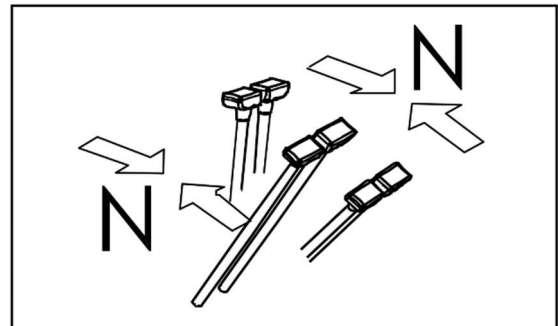

- 4) Push the throttle forward to the end and pull the stop handle back to the end (if equipped).
- 5) Turn the starter key to the "OFF" position (all indicator light are off).
- 6) Reset the stopping handle after the engine stops.

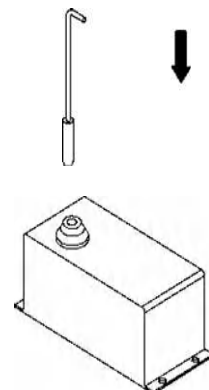

- 7) Lock the platform.
- 8) Use the pilot valve safety handle to pull up the left control box and put the machine in the locked position.

## **4.14. After operation**

### **4.14.1. Check**

Check the engine water temperature, oil pressure, fuel pressure, fuel level, etc. on the digital monitor of the machine.

### **4.14.2. Lock up**

Lock the following areas.

A Fuel tank filling port

B Engine hood

**ATTENTION: When opening the hood, no one should stand at the back of the hood, the engine hood might pop up and hurt people.**

## **4.15. Loading and unloading and transportation**

### **4.15.1. Safety rules**

- 1) Run the engine at low speed and operate the machine slowly when loading/unloading.
- 2) Do not load/unload the machine when it is in automatic warm-up state.
- 3) If the automatic warm-up is canceled during the loading/unloading operation, the speed will change suddenly.
- 4) Loading/unload the machine on solid, level ground. Keep a safe distance from the edge of the road.
- 5) Use a ramp of sufficient width, length, thickness and strength. The width of the hitch should be of 1.2-1.5 times the width of the track. To avoid any accidents, it

is recommended that the loading/unloading slope should be less than 15°, or the length of the ramp should be more than 3.5 times its height. When using a mounded slope, the mounded soil should be completely compacted and measures should be taken to prevent the slope from caving in.

- 6) To prevent the machine from slipping on the ramp, remove all soil and dirt from the tracks before starting. Make sure the ramp surface is clean and free of water, snow, ice, grease or oil.
- 7) Do not steer on the ramp or the machine will be in danger of tipping over. If you must change the climbing path, exit the ramp, correct the direction, and then enter the ramp again.
- 8) Do not use the work device for loading and unloading, it is dangerous.
- 9) When on a ramp, only maneuver the travel lever.
- 10) When travelling from the ramp onto the vehicle, the machine's center of gravity may change suddenly and there is a risk of losing balance. Therefore, travel slowly when crossing this area.
- 11) When turning the upper on the transport vehicle, the transport vehicle is unstable. Therefore, retract the work device and turn it slowly.
- 12) The wheels of the transport vehicle should be wedged when the excavator is getting on or off.
- 13) Use wooden wedges to keep the excavator in a fixed position on the transport vehicle during transportation. Tie the excavator to the transport vehicle with a rope strap.
- 14) Before finishing the work and leaving the seat, the operator should first lift the left control box to disconnect the pilot oil circuit to avoid malfunction of the machine due to mistake or unintentional touching of the lever.
- 15) Before going up and down the ramp, be sure to put down the positioning puller of the rotary platform to prevent the platform from rotating.

#### **4.15.2. Loading**

- 1) Loading should only be done on solid and level ground, and keep a certain safety distance from the edge of the road.

2) Apply the brakes to the transport vehicle properly and put pads under the tires to ensure that the transport vehicle does not move.

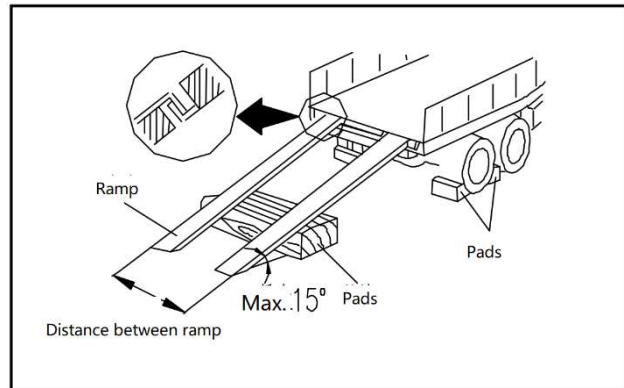

3) Install a ramp between the transport vehicle and the machine and make sure that both sides of the ramp are on

the same level. The maximum slope of the ramp should not exceed 15 degrees. Adjust the distance between the ramps to match the center of the tracks.

4) Lock the slewing platform.

5) Align the excavator with the hitch ramp, with the dozer at the rear. For safety, keep the excavator close to the ramp and slowly climb up the ramp.

**ATTENTION: While on the ramp, operate only the travel lever, not any other lever or pedal.**

6) Stop the machine and extend the arm (position B in the diagram) so that the front part of the excavator tracks tilts down onto transport vehicle, make sure not to let the work device touch the body of the transport vehicle while the machine is tilted down.

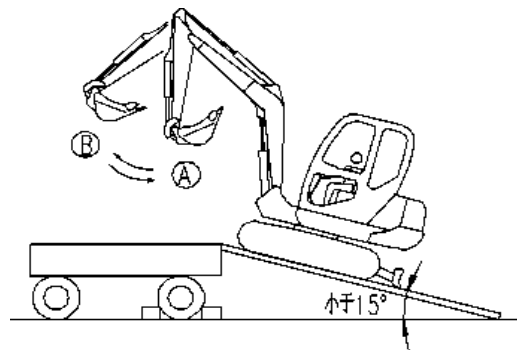

7) Lower the arm and drop the bucket on the floor, lower the dozer and stop the machine at the specified position on the transport vehicle.



**WARNING: Before the driver leaves the seat after finishing work or maneuvering, first pull up the safety locking handle and lift the left control box to disconnect the pilot oil circuit to avoid malfunctioning of the machine due to mistakes or unintentional hitting of the lever.**

**ATTENTION: Select a transport vehicle that matches the weight and**



**dimensions provided in this manual.**

**4.15.3. Fixing the machine on the transport vehicle**

- 1) Set up the working device.
- 2) Turn off the engine and remove the key from the starter switch.
- 3) Lock the platform.

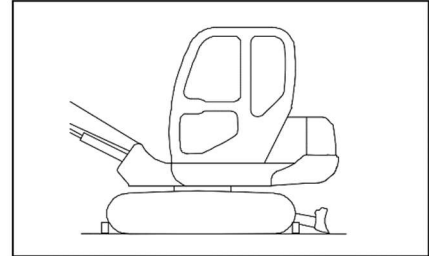

- 4) Lock the cab and the engine hood.

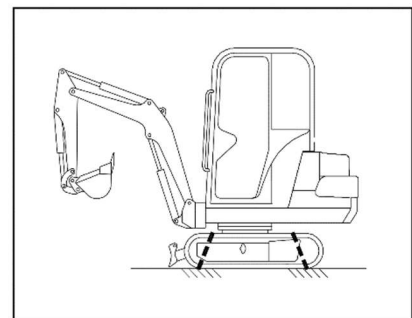

- 5) Place pads under the ends of the tracks to prevent the machine from moving during transport and tie the machine securely with wire rope. Take special care to secure the machine so that it does not slide to one side.

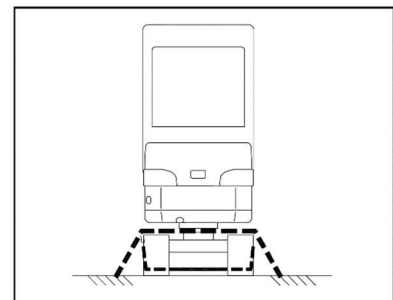

**4.15.4. Unloading from the transport vehicle**

- 1) Load and unload on a firm, level surface and maintain a safe distance from the edge of the road.
- 2) Apply brakes to the transport vehicle and place pads under the tires to ensure that the vehicle does not move.
- 3) Install a ramp between the transport vehicle and the machine. Make sure that both sides of the ramp are on the same level. Make sure that the ramp slope does not exceed a maximum of 15 degrees. Adjust the distance between the ramps to

match the center of the tracks.

- 4) Remove the rope holding the machine in place.
- 5) Start the engine. In winter, perform a thorough warm-up operation.
- 6) Lower the left control box.
- 7) Lift up the arm and bucket, and lift the dozer.
- 8) Check that there are no obstacles within the excavator's range of motion.
- 9) Pull up the platform locking pin, make the platform rotate 180 degrees, the digging device is facing the slope, and the excavator is in the forward direction.
- 10) Slowly travel to the top of the hitch, extend the arm outward, make the excavator track tilt down to the ramp, and then slowly travel to the ground.

#### **4.15.5. Lifting machine**

##### **A) Safety rules**

- 1) Do not lift the machine when there are people on the machine.
- 2) Be sure that the wire rope used to lift the machine is strong enough to carry the weight of the machine.
- 3) Do not lift the machine in any position other than the one provided in the following procedures, otherwise there is a risk of tipping over.
- 4) Do not lift the machine with the superstructure turned to the side. Before lifting, rotate the platform so that the work device is oriented in the same direction as the dozer and so that the tracks are parallel to the superstructure.
- 5) When lifting, keep the machine level.
- 6) Do not walk under the machine when lifting.

##### **B) Lifting procedures**

**ATTENTION: Lifting procedures apply to machines of standard technical specifications. The hoisting devices should have capacity sufficient to lift the weight of the machine.**

For machines equipped with lifting holes, lift the machine according to the following procedure.

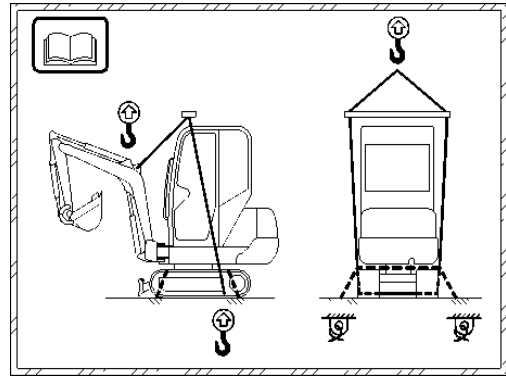

- 1) Rotate the platform so that the working device is oriented in the same direction as the dozer. Start the engine and set the work device to the position shown on the right, with the boom fully raised and the arm and bucket fully retracted.
- 2) Turn off the engine and lift up the left control box so that the machine is in a locked position.
- 3) Check that the area around the machine is safe, then get off the machine. Close the cab windows, doors, windows and hood.
- 4) Hook firmly to the lifting hole on the boom (the lifting hole is labeled with a lifting hook symbol), and pass the wire rope between the drive wheel and the first supporting wheel.
- 5) Select the lifting position of the wire rope so that it is directly in the center of gravity of the machine (the center of gravity of this model is above near the center of rotation), as shown in the picture above.
- 6) When lifting, check whether there are leakage from the hydraulic line at the top of the boom cylinder. Such leakage will change the position of the working device.
- 7) When the machine leaves the ground, stop the lifting operation and check if the machine is in balance. When the machine is stable, continue the lifting operation.

## 4.16.Operation in cold/hot climate

### 4.16.1. Operation in cold climate

Cold weather can cause special problems. Proper cold weather maintenance will

extend the life of the machine.

- 1) Electrical system: Keep the battery clean and fully charged. Check the battery cables and connectors, clean the terminals and apply a layer of grease to prevent rusting.
- 2) Lubricant: Use lubricant with suitable viscosity at each joint. Please use the lubricant recommended by this manual.
- 3) Fuel system: Check to see if the fuel is compatible with the cold climate. Change to a lower viscosity fuel.
- 4) Check for water in the fuel system. The cold weather will concentrate water in the fuel tank. Check the water in the fuel filter every 50 hours of operation. If no water is present, extend the inspection interval. If there is water, check the fuel tank.
- 5) Cooling system: Before operating the machine in cold weather, check the coolant and adjust the proper mixing ratio. Use antifreeze suitable for ambient temperature conditions.
- 6) Working device: Before operating the machine, put it in low gear and start it slowly, then stop the machine and operate the working device for about 10 minutes or until all hydraulic cylinders are working properly.

#### **4.16.2. Operating in hot weather**

To prevent damaging the machine, do as follows.

- 1) Ensure that the coolant level in the radiator is normal.
- 2) Check the radiator before the hot season starts and replace the coolant if needed.
- 3) Remove all dirt from the radiator and engine surface.
- 4) Check the fan belt.
- 5) Use a lubricant with the right viscosity.
- 6) Use the right mixture of coolant in the cooling system.
- 7) Check the air filter frequently when operating in extremely poor conditions such as dusty environment.

## 4.17.Storage of the machine

### 4.17.1. Preparation before storage

When storing the machine for a long time, do the following steps.

- 1) Clean and rinse the machine before put it indoor. If you have to store the machine outdoor, choose a flat surface and cover the machine with tarp.
- 2) Apply a thin layer of grease to the metal surface of the piston rod. Lubricate all lubrication points.
- 3) Remove the battery, charge it, and store it in a dry place where it will not freeze.
- 4) Drain the engine oil in a hot state and fill it with anti-corrosion oil. The anti-corrosion oil used is MIL-L-21260 for piston engines. Winter storage need 1 or 2 SAE10W oil, summer storage need SAE30 grade oil.
- 5) Add 4-6% of the same type of anti-corrosion oil to the fuel and mix the two well together. To prevent condensation, refill the tank with this fuel mixture.
- 6) Check the anti-freeze performance of the coolant and make it at least -20°C by adding antifreeze. If the coolant does not contain anti-corrosion agent due to the climate, add anti-corrosion agent (e.g. 5% anti-corrosion agent according to MIL-G4339C).
- 7) Start the engine and run for more than 15 minutes with different speed but no load. (When draining the hydraulic parts and reducer , the operator should also run with no load and then replace oil before storage.)
- 8) Close the inlet of the air filter and the outlet of the exhaust pipe. It is recommended to use thick plastic paper and adhesive tape.
- 9) Lock the platform, lift the left control box, so that the levers and pedals are in a locked state.
- 10) Place the shut-off valve for attachments in locked position. Install a screw plug on the elbow.
- 11) Keep the machine clean and store it in a dry place.

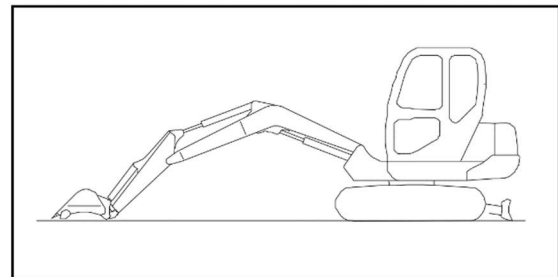

**ATTENTION: When storing the machine, position the machine as shown in the**

**figure to the right to protect the cylinder piston rod from rusting.**

#### 4.17.2. During storage

- 1) During storage, operate the machine once a month to apply a fresh film of oil to the surfaces of the moving parts. Also, charge the battery.
- 2) Drive the tracks to prevent rusting.
- 3) Rotate the track.



**WARNING: If the machine is indoors, open the windows and doors to ventilate.**

#### 4.17.3. Returning to work after storage

When using the machine after long storage, do the following before using it.

- 1) Wipe off the grease on the surface of the cylinder piston rod.
- 2) Fill all parts with oil and grease.
- 3) When the machine has been stored for a long time, water in the atmosphere will enter the oil. Before starting the engine or after starting the engine, check the oil in all parts. If there is water in the oil, replace all the oil.

**ATTENTION: 1 Under normal climatic conditions, the storage method described earlier will allow the excavator to be stored for one year. However, after 6 months of storage, the parts should be rotated for 15 minutes with no load. At the same time, each part should be filled with lubricant.**

**2 Before putting the excavator into use again after a long period of storage, do the necessary work and various checks. After a year of storage, replace the oil in reducer and hydraulic circuit.**

#### 4.18. Causes of technical failures and solutions

- **The engine cannot be started or is difficult to start**

- 1) The starter motor is faulty - Fix or replace the starter motor
- 2) Insufficient battery charge -Charge or replace with new battery
- 3) Preheat circuit or preheat plug improperly used -Repair or replace the preheat plug
- 4) Injection timing is not correct -Check the injection timing
- 5) Fuel delivery line is blocked -Clean the fuel line
- 6) Fuel filter blockage -Clean or replace fuel filter
- 7) Water, dust or air in fuel system -Vent air, clean fuel line
- 8) Dirty injector nozzle or low injection pressure -Repair at local service point
- 9) Failure of injection pump -Consult after-sales service
- 10) Insufficient fuel -Add oil
- 11) Obstruction in the intake and exhaust system -Clean the intake and exhaust system

- **Engine shocks, irregular running or stoppage**

- 1) Large amount of gas - Consult after-sales service
- 2) Fuel filter blocked -Clean the filter
- 3) Dirt or air in the fuel system -Exhaust and clean the oil circuit
- 4) Filter blocked, dirty or defective nozzle -Repair at local service center
- 5) Damaged high-pressure fuel line -Replace high-pressure fuel line
- 6) insufficient fuel -Add oil
- 7) Speed regulator can not be adjusted -Consult after-sales service
- 8) Faulty injection pump -Consult after-sales service
- 9) Injection timing is not correct or the nozzle is stuck -Check the injection timing, check the nozzle.

- **Engine power drops**

- 1) Fuel mixed with air -Vent air
- 2) Oil supply is not smooth -Check and clean
- 3) Injection timing change -Adjust according to the specified value
- 4) Injectors work poorly -Check the working pressure and oil injection atomization
- 5) Air filter is blocked -Clean the filter element
- 6) Incorrect intake and exhaust valve clearance or valve not sealed -Adjust valve clearance
- 7) Bad cylinder gasket, air leakage -Replace the cylinder gasket
- 8) Injection pump is not working well -Check with after-sales service
- 9) Engine is overheating -Check if the coolant used is correct. Check if the water pump and belt are too loose, if so, repair or replace them, and remove the blockage in the waterway

- **Engine overheating**

- 1) Coolant level is too low -Add coolant
- 2) Temperature sensor failure -Change new sensor
- 3) Air filter blockage - clean the air filter
- 4) Fan belt loose or defective -Retighten or replace
- 5) Dirt in the cooling system -Clean
- 6) Low oil or too much oil -Replace oil

- **Oil pressure is too low**

- 1) Oil level is too low -Add oil
- 2) Oil filter blockage -Clean the oil filter
- 3) Oil leakage in the line -Tighten and replace



- 4) The engine cooling water temperature is too high - Correctly prepare the coolant mixture ratio or contact the local after-sales service

- **Grey and black smoke from the engine**

- 1) Poor fuel quality - Use the correct fuel
- 2) Clogged air filter - Replace filter element
- 3) Injection timing is not correct -Adjust according to the specified value
- 4) Nozzle atomization is poor -Check, change parts

- **White smoke from the engine**

- 1) Poor fuel quality -Use the correct fuel
- 2) Excessive engine oil -Restore the recommended oil level
- 3) Injection timing is not correct -Adjust according to the specified value
- 4) There is water in the cylinder and fuel -Check and change fuel

- **Battery can not be charged**

- 1) loose connection or rust - clean or tighten
- 2) Generator belt is loose or defective -Tighten or replace
- 3) Generator does not charge -Consult after-sales service
- 4) Electrolyte of the battery is not working -Replace
- 5) The battery electrode plate is not working -Replacement

- **Starter motor does not work or slow rotation**

- 1) loose connection or rust - clean or tighten
- 2) Insufficient battery charge -Replacement
- 3) Wiring damage -Consult after-sales service

- **Engine running while the generator alarm light is on**

- 1) generator failure - ask after-sales service
- 2) Faulty electronic regulator -Replacement
- 3) The wiring is faulty -Servicing

- **Hydraulic system components too slow**

- 1) Hydraulic oil cold -Operate the machine to heat up the hydraulic oil
- 2) Pilot system pressure too low -Consult after-sales service
- 3) Wrong hydraulic oil -Use correct hydraulic fluid
- 4) The engine speed is too slow -Consult after-sales service

- **High hydraulic oil temperature**

- 1) Incorrect hydraulic oil -Use correct hydraulic fluid
- 2) Oil circuit is blocked -Consult after-sales service
- 3) Hydraulic oil filter is blocked -Clean or replace
- 4) Worn oil pump -Consult after-sales service
- 5) Oil cooler blocked -Clean the oil cooler
- 6) Faulty oil cooler -Consult after-sales service
- 7) High pressure of main safety valve or rotary system relief valve -Consult after-sales service
- 8) Oil is too dirty -Change the oil
- 9) Faulty sensor -Replacement

- **Hydraulic oil emulsification**

- 1) Air leakage in the line between the oil tank and the pump -Tighten it
- 2) Wrong hydraulic oil -Use correct hydraulic fluid
- 3) Water in hydraulic oil -Change oil

4) Oil level is too low – Add oil

- **Oil pressure too low or no pressure**

- 1) The hydraulic pump is damaged -Check with after-sales service
- 2) Insufficient oil in the system -Add oil
- 3) Faulty safety valve -Consult after-sales service

- **Damage to the hydraulic pump**

Consult after-sales service

- **All components stop working**

Hydraulic pump damaged-consult after-sales service

- ◆ **Noisy oil pump**

- 1) Lack of hydraulic oil -Fill up
- 2) Air leak in the suction pipe -Repair or replace

- ◆ **Oil pump noise remains the same**

- 1) Damaged auxiliary pump - Replace
- 2) Hydraulic safety control device does not work -Check and repair

- **Cylinder or motor is not working**

- 1) Hydraulic pump is damaged -Consult after-sales service
- 2) The main safety valve pressure becomes low -Re-adjust the pressure
- 3) Low hydraulic oil level -Add oil
- 4) Oil suction filter is blocked -Clean the oil filter
- 5) Damaged oil seal -Repair or replace
- 6) Damaged piston rod causing oil leakage -Repair or replace
- 7) Pilot valve malfunction -Replacement

8) The pilot valve is broken or leaking oil -Repair or replace

- **Two travel motors do not work**

Oil stringing in the central rotary joint - Consult after-sales service

- **One travel motor does not work**

1) Walking device is damaged -Consult after-sales service

2) The control mechanism is damaged -Repair

- **Abnormal walking function**

1) Tracks are too tight or too loose -Re-adjust

2) Oil pump performance decreases -Consult after-sales service

3) Track frame deformed -Repair or replace

4) There are debris or rocks in the track chain -Take out and repair

5) Oil leak from control valve -Consult after-sales service

6) Motor performance decreases -Consult after-sales service

- **Abnormal Rotation function**

1) Low performance of oil pump -Consult after-sales service

2) Swing motor is damaged -Consult after-sales service

3) Pilot valve does not work -Consult after-sales service

- **Rotation is not continuous**

1) Swing gear is worn out -Consult after-sales service

2) Slewing bearing or ball damage -Contact after-sales service

3) Lack of grease -Consult after-sales service

4) Oil leakage from control valve -Contact our agent

- **Air condition system noise**

- 1) Clutch noise caused by loose electrical connector -Tighten the connector or repair it
- 2) Loose belt -Tighten moderately, replace if broken
- 3) Blower fan blade is loose -Reinstall tightly
- 4) Blower operation is not normal -Repair or replace
- 5) Electronic fan is not running properly -Repair or replace
- 6) Compressor bearing damaged -Replace
- 7) Tension wheel bearing is damaged -Replacement

- **Air condition does not work**

- 1) Electrical circuit failure -Repair or replace
- 2) Air conditioner switch malfunction -Repair or replace
- 3) No refrigerant -Leak detection, repair, refrigerant charging
- 4) System blockage -Clean or replace
- 5) Belt slack or broken -Adjust or replace
- 6) Expansion valve malfunction -Clean or replace
- 7) Compressor not running properly -Repair or replace
- 8) Pressure switch malfunction -Replacement

- **Air condition Intermittent**

- 1) Wiring contact is poor -Conditioning
- 2) Slack belt -Adjust the belt properly
- 3) Improper adjustment of air conditioning switch coldness -Re-adjust
- 4) The system contains too much water, internal ice blockage -Replace the dry bottle
- 5) Electronic fan or its relay is damaged -Repair or replace

## **5. Maintenance**

### **5.1. General knowledge of maintenance**

#### **5.1.1. New machine break-in**

The first 100 hours of the machine is the break-in period. During this period, the machine should be used carefully and should not be used with excessive load and high intensity work. The first 50 hours of the break-in period, only 80% of the work load is allowed. The use of the machine during the break-in period affects the service life of the machine.

After the first 50 hours of operation, the machine should be serviced for the first time according to the inspection and maintenance chart, and the relevant fluids and filters should be replaced. At the same time, check the contamination level of the hydraulic oil, the value of which should not be greater than NAS9 level. Otherwise, replace the hydraulic oil.

When the hydraulic system is not working, the engine should not be allowed to run at high speed.

Only when the hydraulic oil temperature is over 20 degrees Celsius, the work device can be operated.

#### **5.1.2. Working in dusty sites**

- Clean the radiator core frequently to avoid clogging.
- Frequently clean and replace the fuel filter.
- Clean electrical components, especially the starter motor and alternator to avoid dust buildup.
- When checking or changing the oil, move the machine to a dust-free area to prevent dust from entering the oil.

#### **5.1.3. Oil and Filter**

Use clean oil and grease and do not allow impurities to mix into the oil container.

After changing the oil or replacing the cartridge, check the old oil and cartridge for metal shavings or impurities. If a large amount of metal chips or impurities are found, report to the supervisor and take appropriate measures.

Do not mix different grades of oil together. If you need to add a different grade, drain the old oil and replace it with a new grade of oil.

#### **5.1.4. Timer Readings**

Check the timer on the dashboard daily to see if it is time for mandatory maintenance based on the number of hours worked.

#### **5.1.5. Use genuine parts**

Using Yuchai Heavy Industry pure parts is an important factor to ensure the normal working of the machine and prolong the service life of the machine.

#### **5.1.6. Waste disposal**

Promote environmental protection, pay special attention to waste disposal by.

- Put the oil drained from the machine into a container, do not drain the oil directly to the ground or pour it into the sewer, drain, river, ocean, or lake.
- When handling hazardous materials such as oil, fuel, coolant, antifreeze, plastic parts, solvents, cartridges, batteries and other hazardous materials, comply with the relevant environmental regulations.

#### **5.1.7. Prevent objects from falling into the machine**

- When opening the fuel tank filler for inspection, be careful not to drop bolts, nuts, gaskets or tools into the machine. Dropping these items into the machine can cause damage and malfunction, and may lead to accidents. If something falls into the machine, take it out immediately.
- Before and after the inspection, make an inventory of the tools and parts used, make sure nothing has fallen inside the machine.

### **5.1.8. Periodic inspection and maintenance**

Regular inspect and do maintenance according to the items listed in the "Periodic Inspection and Maintenance Schedule" to ensure the normal operation of the machine and extend its service life. Be sure to follow the inspection and maintenance cycle.

### **5.1.9. Review after inspection and maintenance**

If you do not review the machine after each inspection and maintenance, unexpected failures can occur, resulting in serious injury or damage. Be sure to check the following:

- Whether some parts that should be inspected and maintained have been missed.
- Whether all inspection and maintenance items have been performed correctly.
- Check that no tools or parts have fallen into the machine. It is very dangerous for parts to fall inside the machine and get caught in the linkage mechanism.
- Walk around the machine, check for leaks or oil leaks and that all bolts are tightened.



## **5.2. Maintenance Summary**

### **5.2.1. Lubricant**

- Use oil of the grade and temperature specified in the "Oil Selection Table" in this manual. Change the oil within the specified time, even if it is not dirty.
- Take care to prevent contaminants (water, metal particles, dust, etc.) from entering the lubricant. Most problems with machines are caused by the introduction of impurities.
- Do not mix different grades of lubricants together.
- Do add the required amount of oil. Too much oil or too little oil can cause malfunction.
- When changing oil, be sure to replace the associated filter element, especially when replacing the oil filter element, add fresh, clean and compliant oil to the new element before installing it.

### **5.2.2. Fuel**

- When storing or adding fuel, take special care not to allow impurities to enter.
- Make sure to use the fuel specified in the "Fuel Selection Table" in this manual. When using fuel, use it according to the ambient temperature, otherwise it will easily solidify at low temperatures (especially below  $-15^{\circ}\text{C}$  ( $5^{\circ}\text{F}$ )). Therefore, it is necessary to replace the fuel with one that matches the ambient temperature.
- To prevent moisture in the air from condensing in the fuel tank and forming water, fill the fuel tank at the end of each day's work.
- Before starting the engine, or 10 minutes after filling the fuel, drain the sediment and water from the tank.
- If the engine has run out of fuel, or if the filter element has been replaced, the air in the fuel line must be drained.

### **5.2.3. Grease**

- Grease is used to prevent twisting and noise at the joints.

- Grease any part if it is inflexible or makes noise after a long period of use.
- Wipe off the grease squeezed out during injecting grease.
- Be careful to wipe off the old grease from each place. Sand or dust sticking to the grease will cause wear of rotating parts.

#### **5.2.4. Coolant**

- Antifreeze must be used in all climates.
- Check the coolant level as required and add it promptly if it is found to be insufficient. Insufficient coolant can cause the engine to overheat.
- Use coolant and antifreeze in the proper mix ratio according to the ambient temperature.
- Don't add coolant when the engine is overheated but not yet cooled.

#### **5.2.5. Filter element**

- Replace all filter elements regularly. However, when operating in harsh conditions, change the filter element in a short period of time depending on the lubricant and fuel used (sulfur content).
- Do not recycle cleaned cartridges (cartridge type) again. Replace it with a new one.
- When replacing the cartridge, check for metallic particles on the old cartridge. If any metal particles are found, contact your Yuchai dealer.
- Do not open the packaging of the spare cartridge before use.

#### **5.2.6. Hydraulic system**

- The hydraulic system is under high temperature during and after operation. When operating, it is also in high pressure condition. Therefore, when inspecting and maintaining the hydraulic system, pay special attention to wait for the temperature to cool down and release the pressure in the hydraulic cylinder line.
- When loosening plugs, screws or hose fittings, do not stand in front of the parts, but loosen them gradually to release the internal pressure before disassembly.

- When inspecting or maintaining the hydraulic tank, be sure to vent air to release the internal pressure.
- Inspection or maintenance of the hydraulic system includes checking the hydraulic oil level, changing the filter element and adding hydraulic oil.
- When disassembling the high pressure hose, check if the O sealing ring is damaged. If damaged, replace.
- When disassembling parts where the type O-ring or gasket is sealed, clean the mounting surface and replace with new parts.
- When installing the hose, do not twist or bent the hose with sharp angle. This can damage the hose and significantly shorten the life of the hose.

### **5.2.7. Electrical System**

- It is very dangerous for electrical equipment to become wet or for the insulation of wires to become damaged. This can cause electrical leakage and lead to machine failure. When flushing the machine, be careful not to allow water to enter the electrical components.
- Maintenance of the electrical system: check and maintain the battery level; replace various light bulbs; replace fuses and relays, etc.
- Do not install any electronic components other than those specified to be installed by Yuchai Heavy Industries.
- When working at the beach, clean the electrical system carefully to prevent corrosion.
- When installing AC or other electrical equipment, connect it to a special power connector. The selected power source should not be connected to the fuse, starter switch or battery relay.

### **5.3. Wear and tear parts**

Parts that are prone to wear and tear, such as seals, cartridges, bucket teeth and dozer plates , should be replaced during regular maintenance checks or when they reach their wear limit

so as not to affect machine performance.

Genuine parts can be ordered from Yuchai Heavy Industries dealer according to the part numbers in the table or the part numbers in the parts catalog.

Item	Part number	Part name	Quantity	Model
	818V-0501200	Hydraulic oil return filter element	1	TL253H
	801-0521500	Oil suction filter	1	WU-63X100-J
		O ring seal	2	15x2.65 GB/T3452.1
		O ring seal	2	18x3.55 GB/T3452.1
		O ring seal	1	22.4 x 2.65 GB/T3452.1
		O ring seal	4	6.5 x 1.5 ISO
		O ring seal	4	8x 1.5 ISO
		O ring seal	2	11 x2 ISO
		O ring seal	3	10x1.9GB/T3452.1
		O ring seal	3	14x 1.9 GB/T3452.1
		O ring seal	3	11.8x2.4GB/T1235
		O ring seal	1	13.8x2.4GB/T1235
		Seal gasket set	3	18 BS/A 18.7x27x2 ISO
		Seal gasket set	2	22 BS/A 22.7x30x2 ISO
		Straight oil cup	5	M10x 1 JB/T7940.1
		Fuses	1	

#### 5.4. Mandatory replacement parts

Some parts are important to safe operation. Among them, certain parts, mainly some oil hoses, ages along the working time. Aged parts becomes a potential safety hazard. Such deterioration are not easy to determine. Therefore, these parts must be mandatory replaced .

If these parts become abnormal before the specified time in this manual, they must be repaired or replaced immediately. When replacing a hose, replace the corresponding seal at the same time.

## 5.5. Oil selection table

Select oil according to the ambient temperature, operating conditions, and other factors. It is necessary to use oil that meets the following specifications.

	lubrication oil or fuel	Temperature	Viscosity	Recommended substitute oil
Engine lubrication oil	CH4 15W/40	-15°C~+40°C		
	CH4 5W-30	-25°C ~ +30°C		
Hydraulic oil	Cold Region: HS46+ Normal Region : HMP46+	-35°C or above	40°C	
		-12°C or above	46 ± 4.5(mm <sup>2</sup> /s)	
Travel reducer lubrication oil	load bearing gear oil (GL-5)	winter & summer		SAE80W/90
Swing reducer lubrication oil	load bearing gear oil (GL-5)	winter & summer		
Guide wheel and carrier wheel lubrication oil	Axis oil Hz-23 lubrication	winter & summer	50°C 20 ~ 25(mm <sup>2</sup> /s)	
Grease	Lithium disulfide grease (#3)	-20° C ~ 160° C		
fuel	Summer: 0 diesel	>0°C		
	Winter: -10 diesel	0°C ~ -5°C		
	-20 diesel	-5°C~-15°C		
	-35 diesel	-15°C~-28°C		
Coolant (Antifreeze) (Ethylene glycol type engine)	JT 225-1996 -25	>-15 °C		
	JT 225-1996 -35	>-25 °C		
	JT 225-1996 -45	>-35 °C		

● **Oil capacity data**

Classification	Unit of measure	Capacity
Fuel tank	L	23
Engine oil	L	3.4
Hydraulic tank	L	20

## 5.6. Tightening Torque

The tightening torque of each mounting bolt and nut on the machine should be referred to the values in the table below. If the bolts or nuts are not tightened to the specified torque, the fastened or connected parts will be loosened or even damaged, causing machine failure or affecting operation.

### 5.6.1. Tightening torque for general parts

Bolt strength grade	Yield strength (N/mm <sup>2</sup> )	Bolt's diagaugage mm							
		6	8	10	12	14	16	18	20
		Tighten Torque Nm							
8.8	640	9-12	22 -30	45 -59	78-104	124-165	193-257	264-354	376-502
10.9	900	13-16	30 -36	65 -78	110-130	180-210	280-330	380-450	540-650
12.9	1080	16-21	38 -51	75-100	131-175	209-278	326-434	448-597	635-847

Bolt strength grade	Yield strength (N/mm <sup>2</sup> )	Bolt's diagaugage mm						
		22	24	27	30	33	36	39
		Tighten Torque Nm						
8.8	640	512-683	651-868	952-1269	1293-1723	1759-2345	2259-3012	2923-3898

10.9	900	740-880	940-1120	1400-1650	1700-2000	2473-3298	2800-3350	4111-5481
12.9	1080	864-1152	1098-1461	1606-2142	2181-2908	2968-3958	3812-5082	4933-6577

### 5.6.2. Tightening torque for hydraulic Hoses

Metric Thread Nuts			
Thread	Tube outer diagaugage	Nm	
		Torque	min./max
M12X1.5	6	20	15 - 25
M14X1.5	8	38	30 - 45
M16X1.5	8	45	38 - 52
	10		
M18X1.5	10	51	43 - 85
	12		
M20X1.5	12	58	50 - 65
M22X1.5	14	74	60 - 88
	15		
M24X1.5	16	74	60 - 88
M26X1.5	18	105	85 - 25
M30x2	20	135	115 -155
	22		
M36x2	25	166	140-192
	28		
M42x2	30	240	210 -270
M45x2	35	290	255 -325
M52x2	38	330	280 -380
	42		

BSP Thread Nut		
BSPP Thread	Nm	
	Torque	min./max
G1/4	20	15~25

G3/8	34	27~41
G1/2	60	42~76
G5/8	69	44~94
G3/4	115	95~135
G1	140	115~165
G1.1/4	210	140~280
G1.1/2	290	215~365
G2	400	300~500

ORFS Thread Nut			
UNF Thread	Spec	Nm	
		min	max
9/16~18	-4	14	16
11/16-16	-6	24	27
13/16~16	-8	43	47
1~14	-10	60	68
1.3/16~12	-12	90	95
1.3/16~12	-14	90	95
1.7/16~12	-16	125	135
1.11/16-12	-20	170	190
2~12	-24	200	225



## 5.7. Periodic Inspection and Maintenance Table

The machine should be regularly inspected and maintained in accordance with the following table, in conjunction with the operating hours of the machine as indicated by the engine timer. If the machine is in rough working condition, or if it is equipped with attachments such as hydraulic breakers, the inspection and maintenance intervals for certain parts need to be shortened.

#	Check	Maintenance intervals					
		10	50	100	250	500	1000
1	Routine inspection						
	Oil, water, fuel for leakage	▲					
	Appearance of mechanical parts and hoses	▲					
	Bolts and hydraulic joints	▲					
	Consoles, lighting, and indicator lights	▲					
	Engine condition	▲					
2	Fuel system						
	Oil levels	▲					
	Condensation			▲			
	Clean oil tank				▲		
	Injection Pressure					▲	
	Filter elements		☆		▲		
#	Check	Maintenance intervals					
		10	50	100	250	500	1000
3	Cooling system						
	Hoses and clamps	▲					
	Coolant level	▲					
	Radiator fan					▲	
	Change coolant		☆				■
	Coolant density	▲					
4	Engine lubrication						
	Oil levels	▲					
	Change oil		☆		▲		
	Change oil filter element		☆		▲		
	Fan belt tension		☆	▲			
	Valve clearance					☆	▲

Cylinder head tightness					☆	▲
Engine support tightness		☆			▲	

#	Check	Maintenance intervals						
		10	50	100	250	500	1000	2000
5	Engine air intake system							
	Empty the dust accumulation tank	▲						
	Clean the air filter element			▲				
	Replace the air filter element					▲		
6	Hydraulic System							
	Check the hydraulic oil level (if necessary, refill)	▲						
	Remove water and dirt from the oil tank				▲			
	Replace the hydraulic oil and clean the oil feed filter							☆▲
	Replace hydraulic oil return and pilot oil circuit filter element				☆	▲		
	Check the system pressure					▲		
7	Battery							
	Check the electrolyte level		▲					
	Check acidity and charging status					▲		
8	Reducer							
	Check oil level and refuel				▲			
	Change oil						☆▲	
	Check the tightening torque of reducer connecting bolts		☆			▲		
9	Tracks							
	Check and adjust the tensioning status of the tracks	▲						
10	Pivot wheel, carrier wheel and guide wheel							
	Check the tightening torque of the supporting wheel mounting bolts		☆			▲		
	Check the oil level of the guide wheel and pallets						▲	
11	Lubrication							
	Lubricate each lubrication point		▲					

▲ means checking on normal cycle; ☆ means performing first maintenance; ■ means to check every year in spring and autumn

## **5.8. General checking**

Make general routine inspection of the machine every day or every 10 hours.

- 1) Leak check to see if there is any oil, water and fuel leakage from all parts of the machine.
- 2) Check whether there are scratches, fractures or deformations in the elastic connections and Attachments.
- 3) Check the fixing and connection of the hydraulic device.
- 4) Check the appearance of mechanical parts.
- 5) Check the working condition of the operating device, control indicator and various indicators.
- 6) Check the working condition of the engine. Exhaust color for any problems, abnormal sound and determine the location of abnormal sound.

## **5.9. Engine Fuel System**

Maintenance instructions

Fuel tank capacity : 23 liters

Oil level check: 10 hours

Drainage and impurities from the fuel tank: 100 hours

Clean the fuel tank : 250 hours

Check fuel injection pressure: 500 hours

Replace fuel filter : 250 hours

### 5.9.1. Oil level check and refueling

The oil level can be checked with the oil level indicator on the right control box panel or by looking at the oil marker tube. Check daily or every 10 hours.

To avoid condensation, the fuel tank should be filled after each day's work. The fuel filler is located on the left hand side of the seat.

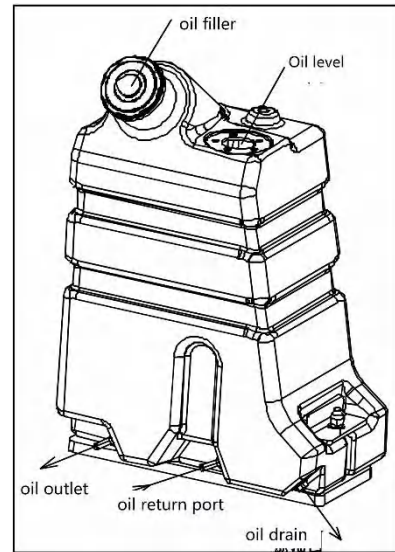

### 5.9.2. Drain water and contaminants from the tank

Condensate and sediment should be removed every 100 hours. Loosen the oil plug to drain condensate and sediment. Reinstall the drain plug as soon as fuel flows out. Depending on the quality of the fuel used, the cycle of condensate drainage can be redetermined by the user.

### 5.9.3. Cleaning the fuel tank

Clean the fuel tank every 250 hours.

- 1) Prepare a container to receive the drained fuel.
- 2) Remove the drain plug and remove the strainer in the fill port. Fill the tank halfway and empty it again.
- 3) Clean the fuel filter and put it back.
- 4) Reinstall the drain plug and fill the tank with fuel through the filter.
- 5) Vent air in the fuel line.

**ATTENTION: When flushing the inside of the fuel tank, do not use trichloroethylene, only diesel.**

#### 5.9.4. Check the injection pressure

Check once every 500 hours.

The injection pressure should be checked periodically according to the intervals shown in the maintenance table and adjusted if necessary. This check should be carried out by our after-sales team!

The efficiency of the engine basically depends on the working condition of the injector nozzle, so it must be maintained regularly to ensure its proper working.

The driver of the excavator should pay attention to the signs shows the injectors are not working properly in order to better use the engine.

A. Single or multi-cylinder banging sound; B. Engine overheating; C. Decreased efficiency; D. Darkened exhaust; E. Increased fuel consumption.

These signs may also be caused by the following reasons, so also do the following checks first.

A. Poor intake and exhaust valve seals; B. Incorrectly adjusted fuel injectors; C. Dirty or damaged fuel filters; D. Poor fuel quality; E. Water in the fuel; F. Dirty or clogged air filter.

#### 5.9.5. Vent air from fuel circuit

If air enters the fuel circuit after replacing the fuel filter, disconnecting the fuel line, cleaning the fuel filter, or by accidentally emptying the fuel tank, the air should be removed before restarting the engine.

- 1) Open the air vent screw on the fuel filter holder.
- 2) Run the filler pump plug until there is no air in the fuel flowing out of the vent screw.
- 3) Close the air vent screw on the fuel filter holder.

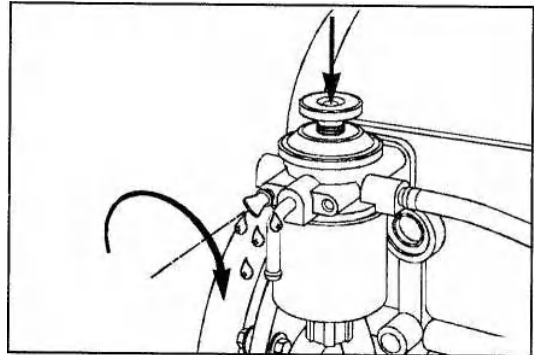

**WARNING: The fuel pressure in the high-pressure fuel line is sufficient to penetrate the skin and may cause serious injury. Gloves**

**and protective clothing should be worn before operation.**

### 5.9.6. Changing the fuel filter

Replace the fuel filter element for the first time after 50 hours of operation and every 250 hours or 3 months thereafter.

#### A) Replace the fuel filter

- 1) Remove the fuel filter.
- 2) Clean the gasket surface of the filter holder with a lint-free cloth.
- 3) Discard O ring.
- 4) Install a new O ring.
- 5) Fill the new filter with fresh fuel and lubricate with clean oil O ring
- 6) Install the fuel filter as specified by the filter manufacturer.
- 7) After replacing the filter element, start the engine and check the filter element sealing surface for oil leakage.

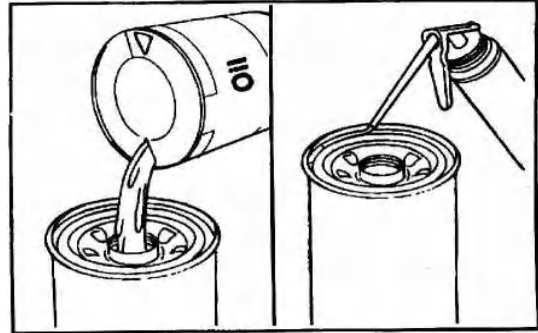

### 5.9.7. Replace the fuel filter

- 1) Remove the fuel filter from the bracket and remove the clamps and rubber hose.
- 2) Install the new filter.
- 3) Fill the new filter with fuel and lubricate it with clean oil.
- 4) Finally, vent air.

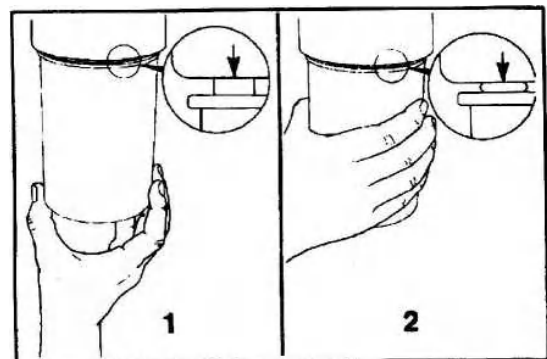

**ATTENTION: To reduce the possibility of fuel leaks, make sure the fuel filter is installed tightly but not too tightly. Excessive mechanical tightening can damage the fuel filter.**

## 5.10.Engine Cooling System

### Maintenance Instructions

Coolant Level Check-----Every day or every 10 hours of work

Check the condition of the rubber hoses and clamps ---Every day or every 10 hours of work

Coolant replacement-----Every 500 hours

Cleaning the radiator blades-----Every spring and autumn

Coolant concentration check ----- Every day or every 10 hours of work

### 5.10.1. Check the coolant level

Check the coolant level in the radiator before starting a new machine and daily or every 10 hours thereafter.

Remove the radiator (water tank) cap and check the coolant level.

When the engine is cold, the coolant level should be between the highest and lowest water level in the balance tank.

Observe the coolant level in the balance tank.

When the engine is cold, the coolant level should be between the highest and lowest water level.

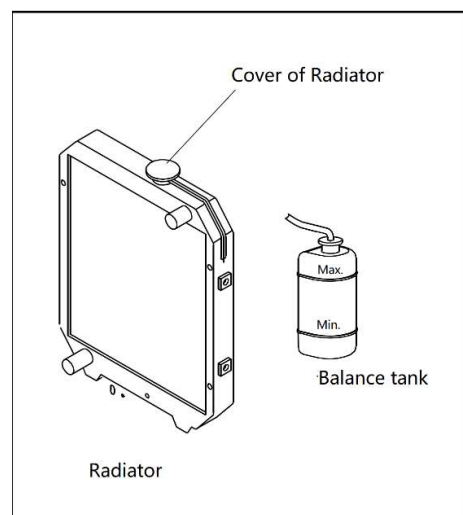

**WARNING: Hot coolant will spray out when the radiator cap is unscrewed. After the system has cooled, loosen the cap slightly and allow the pressure to release completely. If the cap is unscrewed too quickly, coolant will spray out and may cause injury.**

### 5.10.2. Check the condition of the rubber hoses and clamps

Check every 10 hours or once a day.

Check the rubber hose, if it is cracked or hardened due to aging, replace it.

Check the hose clamps for tightness and replace them if they are loose or damaged.

### 5.10.3. Clean and inspect the radiator blades

Clean every 500 hours.

Dust on the exterior of the radiator (water tank) will affect the cooling effect and must be cleaned promptly.

Open the hood and use high-pressure water or compressed air to blow away the dust or leaves and other debris that block the radiator blades. At the same time, clean the grid in front of the oil cooler. For machines equipped with air conditioning, also clean the condenser blades.



**WARNING: Always use goggles, dust masks and other protective masks when using compressed air, high-pressure water or steam to clean.**

**ATTENTION: To prevent damage to the radiator, high-pressure water or compressed air nozzles should be 500mm from the radiator (water tank) surface. Damaged radiator can cause water leakage or overheating. Check the radiator daily in dusty sites, regardless of the maintenance interval.**

### 5.10.4. Coolant replacement

The first change after 50 hours of operation.  
Replace every 1000 hours thereafter.

- 1) Remove the radiator (water tank) cover and unscrew the water valve to allow the coolant to flow out.
- 2) Clean the cooling circuit, close the drain valve, fill with special cleaning fluid, then start the engine, let the engine run at low speed for 10

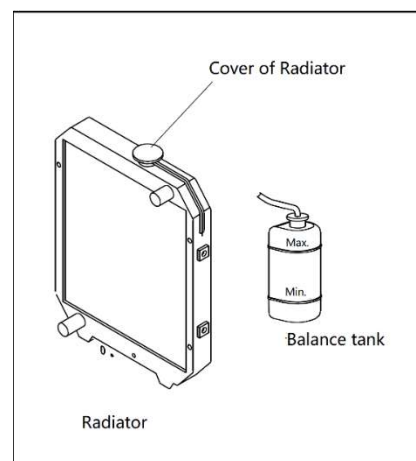



minutes, and then stop to release the cleaning fluid.

- 3) Shut off the drain valve again;
- 4) Fill the coolant, let the engine idle for a few minutes, so that the coolant go through the entire cooling circuit.
- 5) Check the coolant level and refill the coolant.



**WARNING: Do not open the radiator (tank) cap of a hot engine. Do not open the radiator cap until the coolant temperature has dropped below 50 degrees. Otherwise, hot coolant or steam may cause injury!**

#### 5.10.5. Check the coolant concentration

Before the cold season starts, check the coolant concentration. The coolant should be able to operate at an ambient temperature of -20°C. If the ambient temperature is lower, the specific gravity of the antifreeze should be increased.



**WARNING: Coolant is toxic. Avoid contact with coolant by children and pets. Dispose it in accordance with local environmental regulations.**



**WARNING: Antifreeze must be used in all climates!**

**Do not use only water as coolant. Otherwise damage may occur due to corrosion.**

**River water contains large amounts of calcium and other impurities. If river water is used, scale can form and adhere to the engine cooling water channels and radiator, causing overheating.**

**Antifreeze is flammable, so take special care to keep it away from open flames.**

**If antifreeze splashes into your eyes, clean them immediately with water and go to hospital as soon as possible.**

## 5.11.Engine Lubrication System

### Maintenance instructions

Oil quantity-----3.4 liters

Oil level check-----Every 10 hours of operation or daily

Oil change or oil filter element change-----Every 250 hours of operation

#### 5.11.1. Oil level check

Check the oil level before starting the new machine and every 10 hours thereafter.

- 1) Park the excavator on a level surface and stop the engine.
- 2) Open the engine hood, take out the oil scale and check, the oil level should be between the lowest (L) and highest (H) marks.
- 3) If necessary, add oil from the oil port.

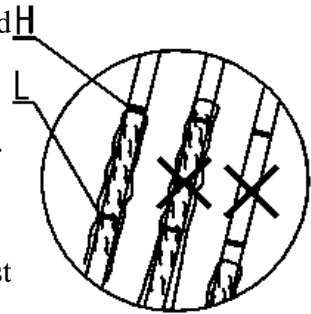

**WARNING: When the engine is turned off, the parts and oil are still hot and can cause severe burns, so wait for the temperature to cool down before maintenance.**

#### 5.11.2. Change the engine oil

Change the engine oil for the first time after 50 hours of operation and every 250 hours thereafter.

- 1) Park the excavator on the horizontal ground, stop the engine and drain the oil while it is hot.
- 2) Remove the oil drain screw and let all the oil flow out.

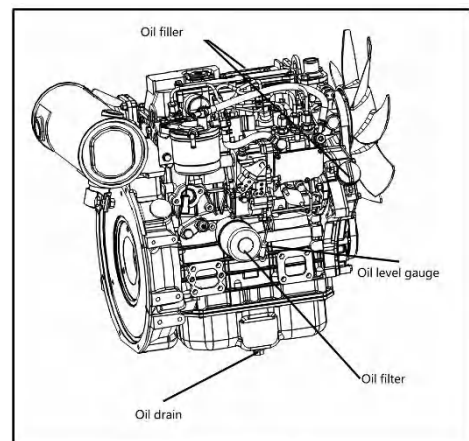

洋马 3TNV76-PYU



**WARNING: Avoid inhaling oil vapor, swallowing or prolonged contact with used oil.**

- 3) Clean the oil drain plug and reinstall it, if the seal is damaged, replace it.
- 4) Open the oiling hole.
- 5) Refill with new oil until the oil quantity reaches the "maximum" mark H of the oil scale.
- 6) Put the oil filler cap on and let the engine run idle for 5 minutes.
- 7) After the engine stops for 10-20 minutes, check the oil level. If necessary, add oil.

### **5.11.3. Replace the engine oil filter element**

First cleaning after 50 hours of new engine operation, and then cleaning or replacement every 250 hours.

### **5.11.4. Oil filter replacement**

- 1) Loosen and remove the oil filter cartridge.
- 2) Oil the gasket of the new filter element and fit it in the ring groove at the end of the filter housing.
- 3) Start the engine and check the seal of the oil filter installation.
- 4) Stop the engine and check the oil level. If necessary, refill the oil.

## 5.12.Engine air intake system

### Maintenance Instructions

Dust collection tank cleaning cycle ----- every 10 hours or daily

Air filter cartridge cleaning cycle ----- every 100 hours

Air filter cartridge replacement cycle ----- every 500 hours

#### 5.12.1. Cleaning of dust collection bin

- 1) Remove the dust container and empty it regularly (once a day for dusty environments).
- 2) Clean the dust container.
- 3) Check the tightness of the filter element by hand.
- 4) Check the inner casing of the filter and do not allow any foreign substance to enter the filter.
- 5) Reinstall the dust container.

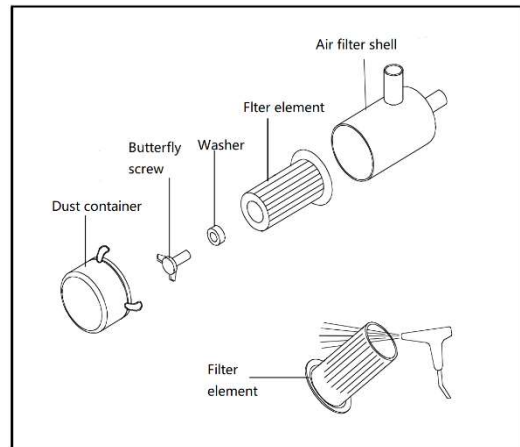

**WARNING: If inspection, cleaning or replacement is performed while the engine is running, dust will enter the engine causing damage to the engine. Turn off the engine before performing these operations. When using compressed air, there is a risk of injury from flying debris. Wear protective eyewear, a dust mask, or other protective equipment.**

#### 5.12.2. Clean the air filter element

Every 100 hours, clean the air filter element.

- 1) Remove and empty the dust container, loosen the butterfly screw and remove the sealing gasket.
- 2) Take out the air filter element and blow it clean with compressed air. The maximum compressed air pressure is 6 Pa. When cleaning, use compressed air to blow from the inside of the filter element to the outside.

- 3) After drying the cartridge (not to exceed 50°C), reassemble the cartridge.
- 4) Never clean the cartridge by tapping it on a hard surface.

**ATTENTION: Before installing the cleaned cartridge or replacing the cartridge with a new one, the cartridge should be checked for damage. Method: Place a light source inside the cartridge to see if there are any holes in the cartridge. If holes are found, the cartridge cannot be used.**

### 5.12.3. Replace the air filter element

Replace the cartridge that has been repeatedly cleaned 6 times or has been used for 500 hours.

- 1) Follow the same procedure as the cleaning operation instruction.
- 2) Test the quality of the new cartridge by above mentioned light check
- 3) Install the new cartridge.
- 4) Install the butterfly screw and dust bin.

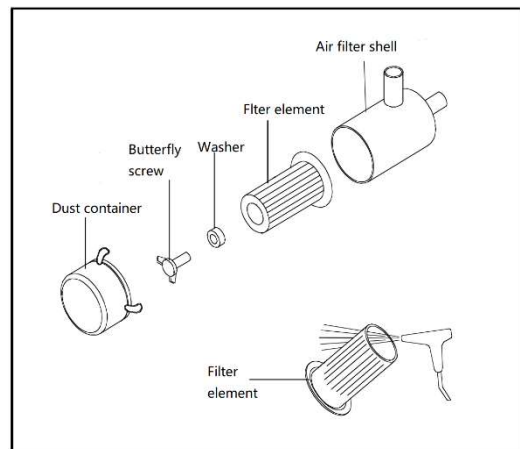

### 5.12.4. Check the air inlet pipe

Check the air inlet pipe daily for signs of possible engine damage such as worn spots, damaged pipes, loose clamps or broken pipes.

If necessary, replace damaged tubes and tighten loose clamps to ensure no leaks in the air intake system.

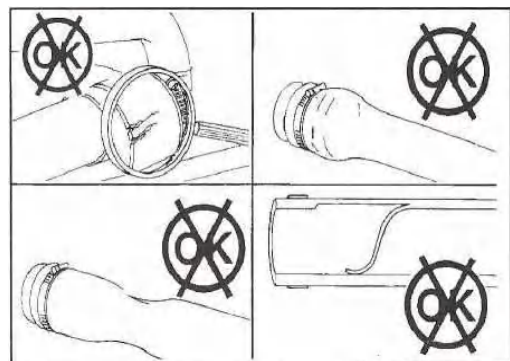

### 5.13. Other engine maintenance



**WARNING: To prevent injury, do not perform maintenance while the engine is running. If maintenance must be performed with the engine running, operate with at least two people and do the following.**

**One person must be in the operator's seat at all times and be ready to shut down the engine. All personnel must keep communicating with each other.**

**Take special care when operating close to fans, fan belts or other rotating objects, as there is a risk of being caught in the parts.**

**Do not drop or insert tools or other objects into the fan or fan belt.**



**WARNING: If the machine is too noisy, it can cause temporary or permanent hearing problems. Wear ear muffs or ear plugs while working when performing engine maintenance and being exposed to noise for extended periods of time.**

- **Check the fan belt tensioning**

The first check is performed after 50 hours of operation. Check every 100 hours thereafter.

To ensure proper generator operation and belt life, the fan belt must be properly tensioned.

For a properly tensioned belt, apply 10 kg perpendicular to the belt between the fan pulley and the generator pulley, and the belt will sink by about 10 mm.

If the belt is found to be damaged, it needs to be replaced.

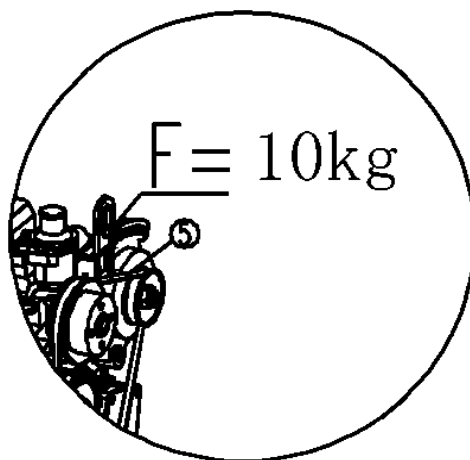

- **For the maintenance intervals and details of other engine components, refer to the Diesel Engine Instruction Manual supplied with the machine.**

## 5.14. Hydraulic system

### Maintenance Instructions

Hydraulic oil tank capacity ----- 20 liters

Oil level check every ----- every 10 hours

Oil filter change Every ----- every 2,000 hours

Hydraulic oil change Every ----- every 2,000 hours

Check system pressure Every ----- every 400 hours



**WARNING: Hydraulic oil or grease, if shot into the skin, can cause serious injury and death. Keep your hands or body away from the pressure oil leak area. A cardboard or paper sheet should be used to check for leaks. If hydraulic oil is accidentally shot into your skin, you should seek immediate medical attention.**



**WARNING: To avoid burns, perform related maintenance only after the hydraulic oil has cooled down or when the oil is cold before daily operation. When removing the flange cover of the oiling port, you need to slowly turn the cover to release the internal pressure in order to prevent the oil from spraying out.**

#### 5.14.1. Check the oil level in the hydraulic oil tank

Check the hydraulic oil tank oil level every 10 hours.

- 1) Park the machine on a level surface.
- 2) Start the engine and operate each cylinder.
- 3) Retract the arm cylinder and extend the bucket cylinder, then the bucket will fall to the ground and the shovel will be put on the ground and the engine will be turned off. As shown in the figure.
- 4) Check the hydraulic oil level gauge

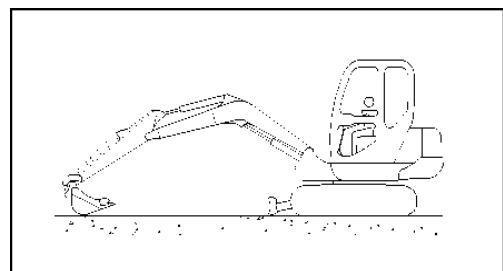

The hydraulic oil level is observed through the oil level gauge.

It is required that the hydraulic oil gauge can be clearly seen in the oil level gauge, do not over fill the tank until you cant see the level in the gauge. This will cause damage to the hydraulic line or spraying of fluid. If the oil is overfilled, stop the engine, wait for the oil to cool and then drain the excess oil from the drain screw port. If the oil level is low or not visible on the oil marker, refill it promptly through the fill port at the top of the hydraulic oil tank.

Hydraulic oil inlet  
(lift the left armrest  
box, and remove  
the cover plate)

Hydraulic oil level  
gauge

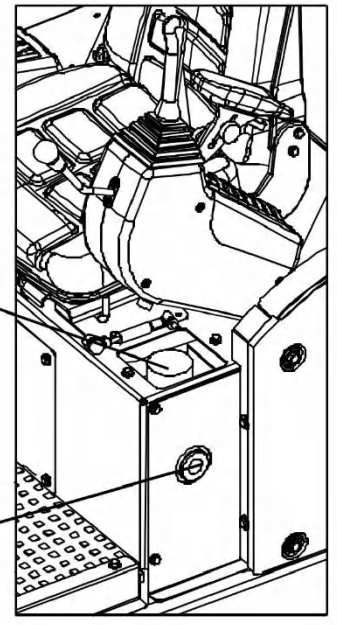

**ATTENTION: The hydraulic oil level will change as the oil temperature rises during operation. Before operation, the oil level will be in the middle of the oil marker tube, after operation, the oil level will raise as heated hydraulic oil expanded.**

#### **5.14.2. Drain the water and dirt in the hydraulic oil tank**

Every 250 hours, drain the water and sediment from the hydraulic oil tank.

- 1) After stopping the machine and waiting for the oil temperature to drop or before starting work each day, vent air from the tank.
- 2) Slowly loosen the drain valve or drain plug at the bottom of the tank (as shown in the figure).
- 3) Drain water or dirt until the hydraulic oil is clear and transparent. Close the drain valve again or tighten the screw plug.
- 4) If there is not enough oil in the tank, refill the oil.



### 5.14.3. Replace the hydraulic oil and clean the oil suction filter

Replace the hydraulic oil as shown in Figure 5-31.

#### **WARNING:**



1) **To avoid burns, drain the oil only after the hydraulic oil has cooled down or when the oil is cold before daily work.**

2) **When removing the flange cover of the oiling port, you need to turn the cover slowly to release the internal pressure, in order to prevent oil from spraying out.**

3) **Be careful not to let water, dirt, mud, etc. enter the oil tank when changing oil.**

#### ● **Cleaning oil tank**

- 1) When the hydraulic oil is in hot state, empty the hydraulic oil.
- 2) Make the piston rod of the hydraulic cylinder fully extended.
- 3) Stop the engine.
- 4) Remove bolt 1, cover 3 and gasket 4.
- 5) When the hydraulic oil tank is empty, remove the filter 5.
- 6) Carefully clean the filter and reinstall it.
- 7) Reinstall the drain screw.
- 8) Fill the hydraulic oil to the highest level.
- 9) start the engine.
- 10) Telescopic each cylinder.
- 11) Extend the hydraulic cylinder piston rod.
- 12) Fill the oil tank to the highest oil level.
- 13) Close the oil tank again and start the engine.
- 14) Retract the piston rod of the hydraulic cylinder.

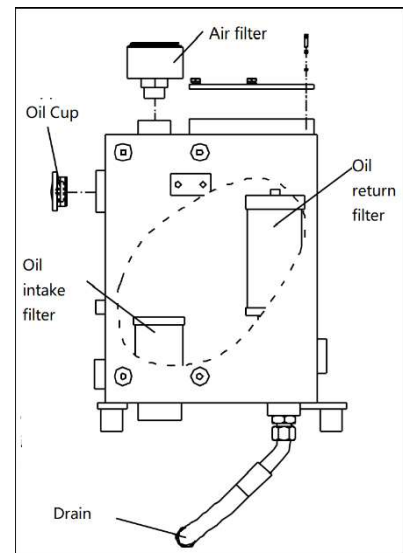

**ATTENTION: After this last operation is completed, the oil level position in the hydraulic oil tank should be slightly raised.**

● **Replace the hydraulic oil return filter element**

First replacement after 2000 hours of work, and every 2000 hours thereafter.

- 1) Fully extended the piston rod of each hydraulic cylinder, and then stop the engine.
- 2) Take off the oil tank screw plug to make it depressurized.
- 3) Unscrew the filter element 6, replace the new filter element (seal the gasket to oil before installation).
- 4) Start the engine and operate the working device.
- 5) Check the hydraulic oil level and refill it if necessary.
- 6) Retighten the screw plug and close the sight hole cover.
- 7) To pressurize the hydraulic tank, retract the piston rod of the hydraulic cylinder.

**5.14.4. Vent air from the hydraulic system**

**A) Vent air from the pump**

- 1) Loosen the air vent plug installed in the drain port and check for oil flow. The air venting is completed.
- 2) Tighten the screw plug after venting is completed.

**ATTENTION: If the pump is not filled with oil when the pump is running, it will cause abnormal high temperature and damage the pump.**

**B) Vent air between the pump and the hydraulic oil tank**

- 1) Start the engine and keep it running at low to medium speed.
- 2) Operate the work device slowly for about 5 minutes to vent air.

**ATTENTION: If the engine is allowed to run at high speed without expelling the air between the pump and the tank, the pump will also be abnormally hot, which could damage the pump.**

**C) Vent air from the cylinder**

- 1) At low engine speed, extend and retract the cylinder to the position that is about 100mm from the end for 4~5 times. (Be sure not to extend or retract to the end of the line)
- 2) Then, operate each cylinder to the end of its stroke 3~4 times.
- 3) Finally, operate each cylinder to the end of its stroke 4~5 times to completely vent air.

**ATTENTION: If you run the engine at high speed or operate the cylinder to the end of its stroke immediately after starting, the air inside the cylinder will damage the piston seal and thus damage the cylinder.**

**D) Vent air inside the rotary motor (when the oil inside the rotary motor housing is drained)**

**ATTENTION: Do not rotate the machine under any circumstances during the air venting period.**

- 1) Idle the engine, loosen the air vent screw and check if oil flows out of the air vent screw.
- 2) If no oil comes out, remove the exhaust screw and fill the motor case with hydraulic oil.
- 3) After finishing the exhaust, tighten the exhaust screw.
- 4) Finally, run the engine at low idling speed and slowly turn the upper part of the car body to the left and right respectively at least twice. Until the exhaust is fully exhausted.

**ATTENTION: If the air inside the motor is not exhausted, the bearings of the slewing motor may be damaged.**

**E) Vent air inside the travel motor (when the oil inside the travel motor housing is exhausted)**

- 1) Run the engine at idle speed and loosen the air vent screw. If oil flows out,

tighten the screw.

- 2) Run the engine at idle speed and rotate the work device 90 degrees so that it is on the side of the tracks. (as shown on the right)
- 3) Raise the machine with the work device so that the track on one side is slightly off the ground and rotate the track for 2 minutes under no load. Repeat for the right and left tracks, turning the tracks equally forward and backward.

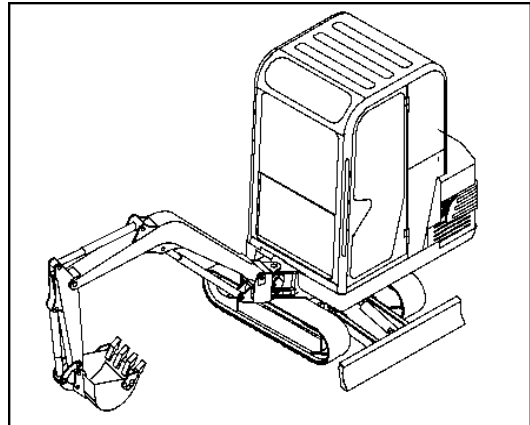

#### **F) Vent air from the attachment**

If attachments are installed, run the engine at idle speed and operate the attachment pedal several times (about 10 times) until air is removed from the attachment oil circuit.

#### **CAUTION.**

- 1) **If the manufacturer specifies a specific way to vent air, follow its specified method.**
- 2) **After completing the air venting operation, turn off the engine and set aside the machine for at least 5 minutes before starting operation again to vent air bubbles in the oil inside the hydraulic cylinder.**
- 3) **Check that there should be no leaks and wipe off any spilled oil.**
- 4) **After completing the venting operation, check the oil level and refill it with oil if it is low.**

#### **5.14.5. Replace the return oil filter element**

Replace the filter element for the first time after 2000 hours of operation and every 2000 hours. The return oil filter is inside the hydraulic oil tank, so.

- 1) Fully extended the piston rod of each hydraulic cylinder, and then stop the

engine.

- 2) Remove the oil tank bolt 1.
- 3) Unscrew the filter element 6 and replace the filter element with a new oil return filter (the seal gasket should be greased before installation).
- 4) Operate the digging mechanism.
- 5) Check the hydraulic oil level and refill it if necessary.
- 6) Retighten the screw plug and close the sight hole cover.
- 7) Retract the piston rod of the hydraulic cylinder.

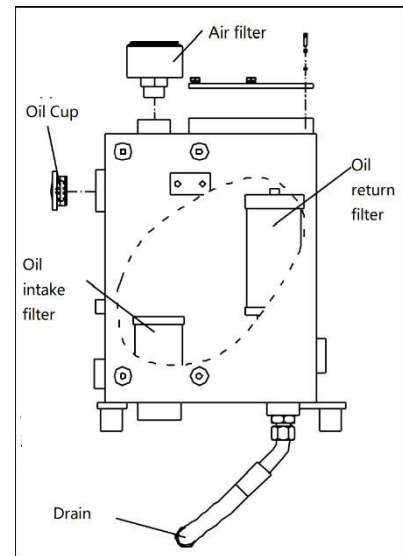

#### 5.14.6. Replace the pilot oil filter element

Replace the first time after 1000 hours after commissioning, and once every 1000 hours.

**ATTENTION: Before removing the filter element, make sure to vent air pressure in the hydraulic oil tank first.**

- 1) Unscrew the oil filter housing.
- 2) Remove the filter element.
- 3) Install the new O ring in the groove of the filter head.
- 4) Before assembling the new filter element, apply a layer of hydraulic oil on the sealing surface of the filter element and put the filter element into the filter head.

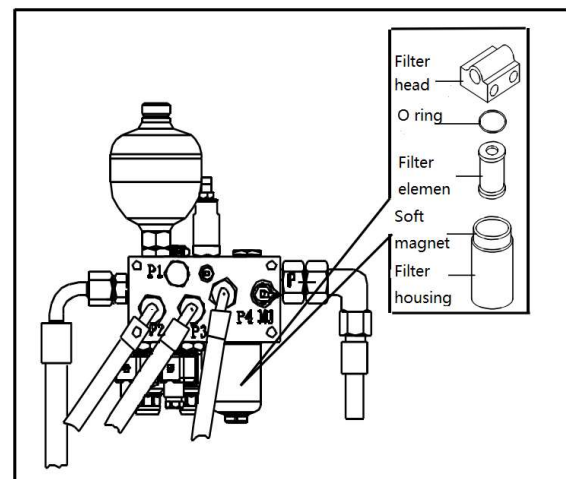

- 5) Clean the oil filter housing and the soft magnet, and pay attention not to allow dirt, dust or water to enter the oil filter housing.

- 6) Tighten the oil filter housing and filter head with a torque of 25~35N.m.
- 7) Connect the pipeline and start the engine at slow speed. Run continuously for 3~5 minutes to vent air from the system.
- 8) Park the machine on a level surface, stop and check the oil level, and refill if necessary. Be careful not to exceed the required maximum oil level limit.

◆ Hydraulic oil and filter element replacement intervals when using attachments (e.g. crusher)

The use of hydraulic hammers increases contamination of the hydraulic system and accelerates corrosion. Compared to excavation units, the replacement intervals for hydraulic oil and filter elements should be shortened to avoid damage to the hydraulic pump and other components. Recommended replacement intervals are shown in the following table: (unit: hours)

Hydraulic hammer operating rate	Hydraulic oil replacement interval	Filter element replacement interval
50%	500	500
100%	250	250

The above table applies to 100% bucket and hydraulic hammer operation. When the hydraulic hammer or bucket operation is intermittent, the replacement cycle should be adjusted according to the length of time the hydraulic hammer or bucket is used.

**ATTENTION: When using a hydraulic hammer, the system pressure should be adjusted according to the requirements of the hydraulic hammer.**

## 5.15. Battery



### **WARNING:**

**1 The battery contains sulfuric acid liquid, which is highly corrosive, please keep it away from children, users should wear protective glasses and rubber gloves when handling the battery.**

**2 The battery will emit hydrogen and oxygen when charging, the battery should be far away from open fire and avoid short circuit.**

**3 The battery shell is made of polypropylene injection, which is flammable and should be kept away from open flame.**

### 5.15.1. Storage of battery

- 1) Machine use liquid lead-acid batteries, which should be stored in a dry, clean and well-ventilated environment at 5~25°C. They should be protected from direct sunlight and at least 2m above the heat source. High ambient temperature will affect the performance of the battery.
- 2) The battery should not be placed upside down or sideways, and should not be subjected to any mechanical shock or heavy pressure.
- 3) The storage period of this series of batteries at room temperature is 6 months, within 6 months the batteries can be used without replenish. Batteries that have been stored for more than 6 months can still be used after replenish.

### 5.15.2. Charging of the battery

The battery generates hydrogen and oxygen by electrolysis of water in the late charging period, which causes water loss, and the higher the charging voltage, the more water loss. There is no need to add water during use, so constant voltage charging method is highly recommended, and constant current charging method is avoided as much as possible.

#### **A) Battery replenishment**

- 1) Constant current charging method.

Charge the battery with a current (A) of one-tenth of the rated capacity for 2~4 hours.

2) Constant voltage charging method

Charge the battery with 16V at constant voltage for 16 hours (maximum current not exceeding 25A)

**B) Normal battery charging**

- 1) Charge the battery with a current of one twentieth of the rated capacity at the rate of 20 hours (A) until the terminal voltage of the battery reaches 14.4V, and continue charging for 2~3 hours.
- 2) Charge the battery with constant voltage at 16V for 24 hours (the maximum current should not exceed 25A).



**WARNING**

**1) The battery generates gas when charging, you should check the vent hole on the battery regularly, so as not to cause battery explosion.**

**2) When charging the battery, the positive terminal of the charger should be connected to the positive terminal of the battery, and the negative terminal of the charger should be connected to the negative terminal of the battery, and reverse charging is strictly prohibited.**

**3) When the battery electrolyte temperature exceeds 45 degree during charging, the charging voltage or charging current should be reduced as appropriate to prevent the electrolyte from sputtering caused by high temperature.**

**5.15.3. Installation of the battery**

- 1) Before installing the battery, please pay attention to the safety signs on the battery label.
- 2) A small amount of Vaseline should be applied to the terminal post before



battery installation to prevent corrosion. The wiring should be secure and reliable. It is strictly prohibited to knock the end post to prevent the battery from seeping acid due to loose end post.

- 3) When installing the battery, the positive terminal of the battery and the positive terminal of the generator should be connected first, and then the negative terminal of the battery and the negative terminal of the generator should be connected.
- 4) Use the upper fixed or lower fixed to fix the battery firmly on the battery frame to avoid the battery damage.

#### **5.15.4. Battery maintenance**

- 1) The battery cover is equipped with an indicator showing the battery charge status. When the indicator shows green, the battery can be used normally. When the indicator shows black, the battery should be charged in time, and when the indicator shows white, it should be replaced immediately.
- 2) The battery should be recharged in time to prevent the degradation of performance caused by battery sulfation.
- 3) Do not overcharge the battery. Or water loss or other issues might shorten the life of the battery.
- 4) If the battery has been installed and used, please take it off and store it in a ventilated and dry place if it is not used for a long time (generally more than 15 days), and recharge the battery once every 3~6 months (depending on whether the indicator is black or not).
- 5) For the questionable battery, please contact with Yuchai Heavy Industry agent in time to solve.

## 5.16.Speed Reducer

### Maintenance instructions

Rotary reducer lubricating oil capacity ----- 0.5 liters

Travel reducer lubricating oil capacity -----1 liter (each side)

Check lubricant oil level and refueling -----Every 250 hours of operation

Change lubricating oil ----- 1000 hours per operation

Check reducer connecting bolt tightening torque ----- 500 hours per operation



**WARNING: The oil in the reducer will become hot soon after the machine is running. When the engine is turned off, the travel reducer and oil are still hot and can cause serious burns. Before starting operation, you must wait for the oil to cool down. Loosen the air vent plug by two to three clicks to relieve the air pressure before removing the plug. It is dangerous to remove the screw plug too fast.**

### 5.16.1. Traveling reducer

Check the lubricating oil level of the travel reducer and add oil

Check every 1000 hours of operation.

- 1) Prepare an Allen wrench.
- 2) Park the excavator on a level surface.
- 3) Rotate the travel gearbox so that the three plugs outside of the gearbox are perpendicular to the ground, then stop the machine.
- 4) Open the screw plug ① and check the position of the lubricant level, which should reach the lower edge of the screw plug hole.

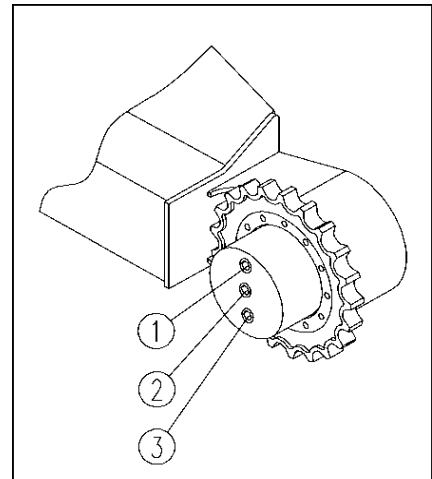

- 5) If necessary, add oil (follow the procedure below to replace the oil)
- 6) Clean the screw plug ① and reassemble it. 2.

### 5.16.2. Replace the lubricant (for each gearbox)

Change the oil for the first time after 1000 hours of operation, and every 1000 hours after that.

- 1) Park the excavator on a level ground.
- 2) Rotate the gearbox so that the three screw plugs outside of the gearbox are perpendicular to the ground, and then stop the machine.
- 3) Drain the oil of the reducer when it is hot.

**ATTENTION: Hot oil, careful not to get burnt.**

- 4) Loosen the screw plug ③ to start draining the oil
- 5) Loosen the bolt ②.
- 6) Add the specified oil from the oil filling hole ① until oil comes out from the oil level check hole ②.

### 5.16.3. Check the tightening torque of the bolts connecting the travel reducer and the slewing reducer

Travel reducer connecting bolts solidity check.

The first inspection is carried out for 50 hours after commissioning, and then once every 500 hours.

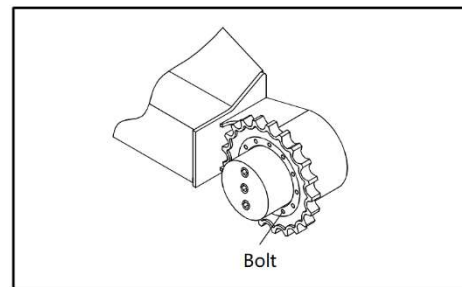

#### 5.16.4. Check the solidity of the connecting bolts of the slewing reducer

The first inspection will be carried out at 50 hours after commissioning and every 500 hours thereafter.

Tighten the bolts connecting the reducer to the platform.

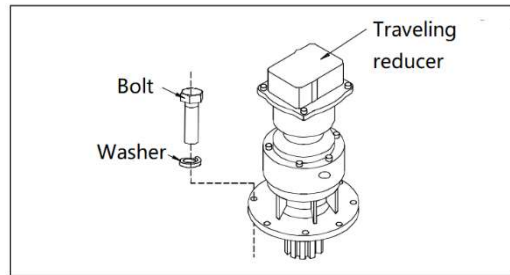

#### 5.16.5. Tracks

##### Check and adjust the tension status of the tracks

Check every 10 hours.

- 1) Park the excavator on a level and hard surface.
- 2) Place the dozer plate at the back and extend the piston rod of the dozer cylinder all the way until the track is slightly lifted.
- 3) Use the bucket to raise the front of the excavator (a in Fig. 1).

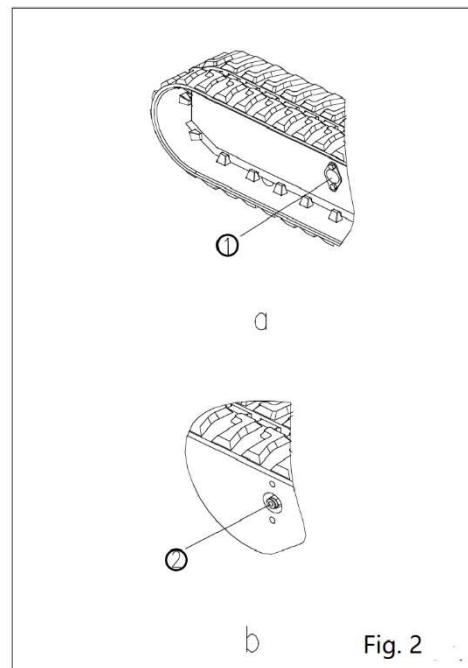
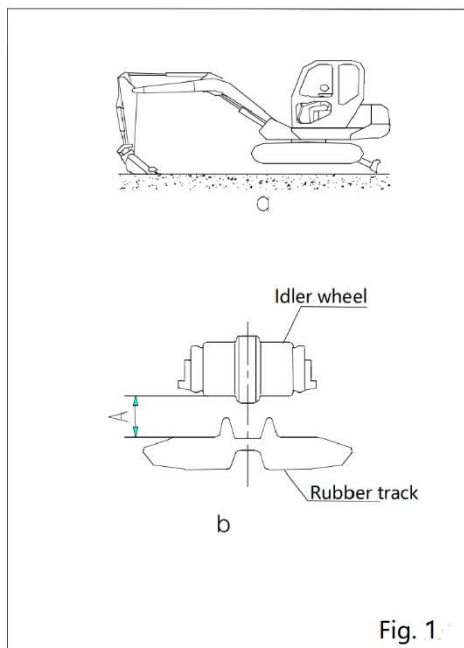

- 4) Tension the tracks properly so that there is 10-15mm deflection between the central supporting wheel and the tracks (Figure 1b).

- 5) Remove the cover ① (a in Fig. 2) from each track frame to expose the oiling nozzle of the tensioning device (② in Fig. 2).
- 6) To loosen the tracks, loosen the joint ② (Fig. 2) to allow the grease to flow out until the correct tension is obtained and then retighten it.
- 7) To tension the track, connect the grease gun connector (supplied as a tool) to the connector ② (Fig. 2). Then use the grease gun to add oil until the correct tension is obtained.

## 5.17. Idler wheel and guide wheel

Checking the idler wheel tightening torque

The first check is carried out after 50 hours after commissioning and every 500 hours thereafter.

The tightening torque of bolt ① should be 110N-mo.

If a bolt is found to be loose, unscrew the bolt, remove the thread locking agent from the bolt teeth, apply thread locking agent to the threaded part, and tighten it according to the specified torque.

If the bolt must be replaced, it must be replaced with a bolt of the same size and strength level.

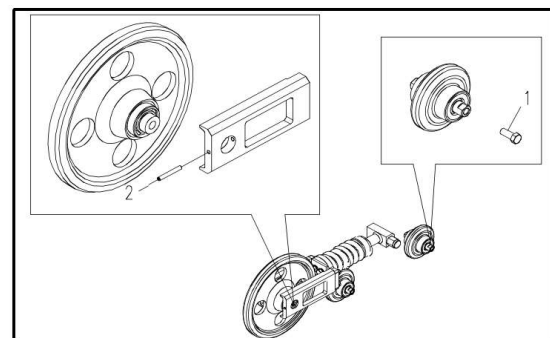

1. Bolt of idler wheel
2. Guid wheel lock pin

## 5.18. Lubrication

Lubricate all lubrication points of the machine every 50 hours.

Lubrication steps.

- 1) Start the work device and lower the bucket to the ground.
- 2) Place the dozer on the ground.
- 3) Stop the engine.
- 4) Wipe the oil cup nozzle clean.
- 5) Lubricate each lubrication point and wipe off the excess grease.

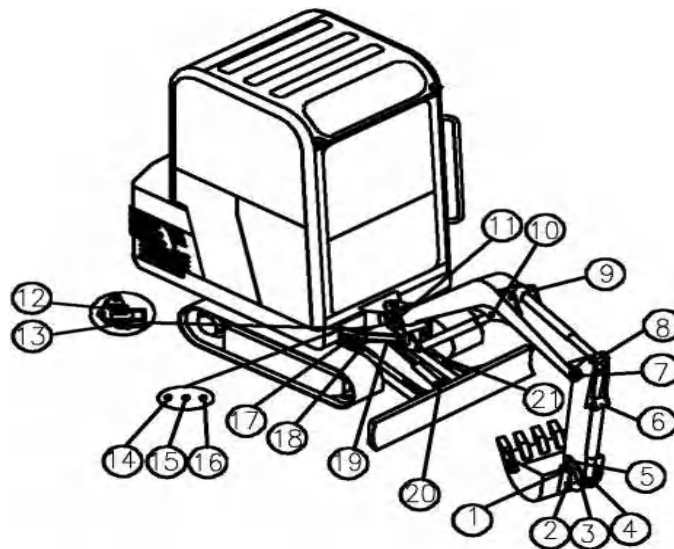

- ① Arm and bucket joints
- ② Connecting rod and bucket point
- ③Rocker and connecting rod point
- ④Bucket cylinder head lubrication point
- ⑤Rocker rod and arm point
- ⑥Lubrication point at the end of the bucket cylinder
- ⑦boom and arm joint
- ⑧ Arm cylinder head lubrication point
- ⑨Arm cylinder end lubrication point
- ⑩ Lubrication point of boom cylinder head
- ⑪ boom and platform joint

- ⑫ Deflecting head upper pin lubrication point
- ⑬ Deflecting head lower pin lubrication point
- ⑭ lubrication point of deflection cylinder
- ⑮ Lubrication point of rotary motor raceway
- ⑯ lubricating point of swing support gear ring
- ⑰ lubrication point of the head of the deflection cylinder
- ⑱ Dozer and frame jointing point
- ⑲ lubricating point of dozer cylinder head
- ⑳ Lubrication point of dozer cylinder end
- ㉑ lubrication point of the end of the boom cylinder

**ATTENTION:**

- 1) **If abnormal noise occurs in the lubrication area, additional lubrication beyond the maintenance cycle should be performed.**
- 2) **When operating the machine for the first 50 hours, perform lubrication every 10 hours.**
- 3) **If you want to excavate in water, lubricate the pin immersed in water before and afterwards.**
- 4) **When operating under heavy loads or deep excavation, lubricate the working device mounting pins before each operation, then operate the boom, arm, bucket and blade several times, and then apply grease. In addition, lubricate every 10 hours.**
- 5) **Please fill the lithium disulfide grease (No.3), and the slewing bearing and pushing device with lithium disulfide grease (No.2).**

## 5.19.Replacement of bucket teeth

Replace the bucket teeth before the bucket teeth socket wears out.



**WARNING: Accidental movement of the work device during tooth replacement is extremely dangerous due to mishandling. Therefore, before replacing the bucket teeth, turn off the engine and lift the left control box so that the work device is in the locked position. Wear the necessary protective gear to prevent the locking pin from flying out when replacing the gear.**

### To replace the bucket teeth

- 1) Place the bottom of the bucket on a cushion for removal. Check that the work device is stable and that the bucket is horizontal. Turn off the engine.
- 2) Remove the bucket teeth by loosening the screws and nuts on the teeth with a hexagonal screwdriver and a screwdriver.
- 3) Clean the mounting surface. Install the new bucket teeth into the seat, then tighten the screws and nuts with a hexagonal screwdriver and a plate to attach the bucket teeth to the seat.

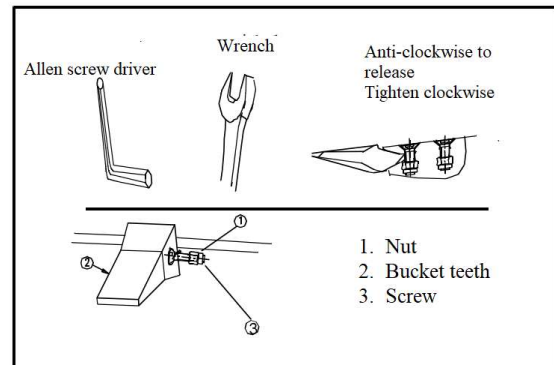
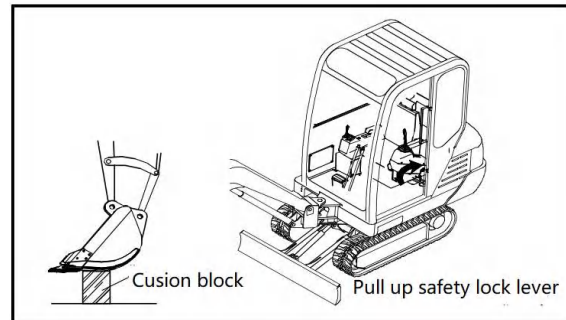



## 5.20.Flushing of the floor mat

Clean the floor mats whenever they are dirty to prevent accidents due to slippery floors and falls.



**WARNING: If the joystick or lever is accidentally touched, the work device or machine may move suddenly, resulting in a serious accident. Therefore, always stop the machine on a firm and level surface before removing the floor mat . Always turn off the engine before removing the floor mat.**

### **Flushing steps of floor mats.**

- 1) Remove the floor mats from the cab.
- 2) Remove the dirt with a brush or rinse the floor mats directly with water.
- 3) Use a dry mop to mop up the floor in the cab.
- 4) After the floor mats are blown dry, put them back into the cab.

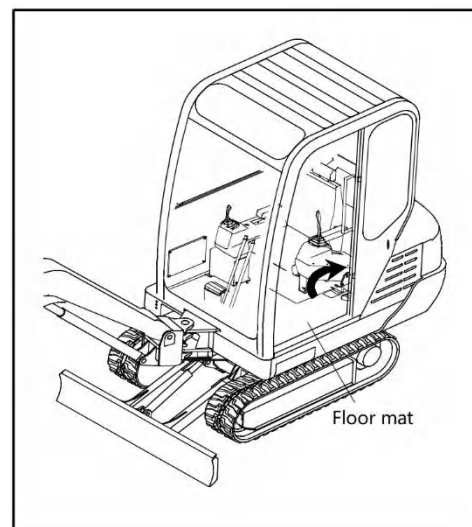

## **6. Attachment Guide**

### **6.1. Safety issues**

If the installation of attachments or options not approved by Yuchai Heavy Industry, Such action will not only affect the service life of the machine, but also cause some safety problems.

When installing attachments not approved by Yuchai Heavy Industries, you should contact Yuchai Heavy Industries dealer first.

If you do not contact Yuchai Heavy Industries, we will not be responsible for any accident or damage.

#### **6.1.1. Safe operation of attachments**

- 1) Attachments have powerful functions. To prevent serious injury or damage, use the attachments properly.
- 2) Read the instruction manual of the attachment thoroughly and do not use the attachment without thoroughly understanding the contents of the manual. If the instruction manual is lost, ask the manufacturer or the attachment sales company to provide a new one.
- 3) Install the necessary front guard on the machine, if necessary.
- 4) Vibration noise can make it difficult for co-workers to communicate operating instructions. Before starting the operation, assign a guider and determine the signals to be used.
- 5) Do not slew to the side with a heavy load on the attachment, especially on slopes where it is very dangerous to do so.
- 6) Machines equipped with attachments such as crushers have a heavier load on the front of the work device and are unstable compared to machines equipped with buckets. To avoid the risk of tipping, do not operate the machine when the attachment is turned to the side.
- 7) When attachments are installed, the machine's swivel range and center of gravity

are different, and the machine can move unexpectedly. Be sure to understand the machine properly.

- 8) Before starting operation, set a perigauge around the machine to prevent people from entering. Do not operate the machine when there are people near the machine.  
-To prevent serious accidents due to mishandling, do not put your foot on the pedal except when operating it.

## 6.2. Removing or installing attachments

When removing or installing attachments, be sure to follow the steps below to ensure safe operation.

- Do the disassembly and installation operations on a firm and level surface.
- When there are more than two people to perform the operation, confirm the signals and observe them during the operation.
- When lifting or carrying heavy objects (over 25Kg), always use a crane.
- When dismantling heavy parts, support the parts before dismantling. When lifting with a crane, pay special attention to the position of the center of gravity.
- It is dangerous to operate while lifting a load with a crane. Have a support fixture ready and make sure it is in a safe condition.
- When placing unloaded attachments or mounting attachments, make sure they are in a stable condition and do not tip over.
- Do not walk under the load lifted by the crane. You should stand in a safe place where there is no danger even if the load falls.



**WARNING: Certification is required to operate the crane. Unlicensed personnel are not allowed to operate the crane. Please contact your Yuchai Heavy Industries dealer for details on disassembly and installation operations.**

## 6.2.1. Attachment Installation/Removal Procedure

### A) Removal Procedure

- 1) Place the attachment on the ground and turn off the engine.
- 2) Turn the start switch to the ON position and push the left joystick box to the working position.
- 3) Operate each work device lever and attachment control pedal two to three times with full range to remove internal pressure in hydraulic lines.
- 4) After confirming that the oil has cooled, lock the rotary valves connected to the inlet and outlet pipes on the bucket side.
- 5) Remove the attachment side hose and tighten the plug to the two outlets with the combination gasket.
- 6) Remove the attachments by removing the pins (2). Then attach the bucket.
- 7) Wrap the unconnected ends of the two hoses of the hydraulic hammer in a clean plastic bag to protect them from dust. Store the attachments.

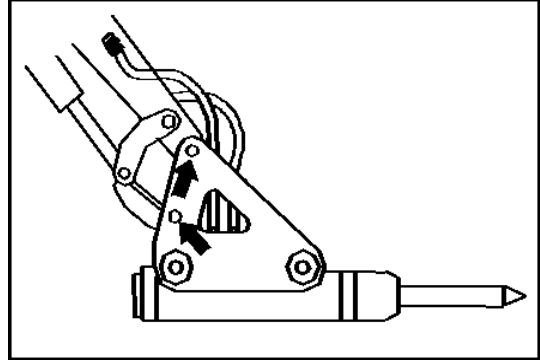

### B) Installation steps

- 1) Remove the bucket.
- 2) Put the attachment on a flat place and connect the arm to the hydraulic hammer and the connecting rod to the hydraulic hammer with pin A and pin B in turn.
- 3) After confirming that the oil has cooled, remove the screws from the outlet and inlet respectively. Be careful not to allow dirt, mud, etc. get into the hose connections. If the combination gasket is damaged, replace it with a new one.

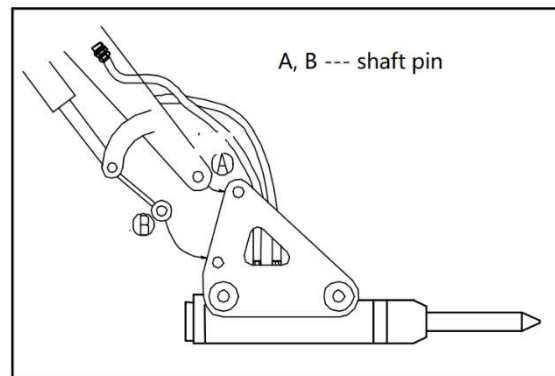

- 4) Connect the attachment side hose. When connecting, check the flow of oil and be careful not to connect the wrong hose.
- 5) Unlock the rotary valves connected to the inlet and outlet pipes on the arm side.
- 6) After installing the attachment, check and confirm the hydraulic oil level is in proper range..

### 6.3. Attachment Operation Guide

This section describes the precautions to be observed when operating an excavator equipped with attachments.

**ATTENTION: Select the attachment that is most suitable for the main unit. The machine models that can be fitted with attachments are different. Please contact your Yuchai Heavy Industries dealer for the selection of attachments and machine models.**

#### 6.3.1. Hydraulic Hammer

##### A. Guide for using hydraulic hammer

The hydraulic breaker is the most common working attachment. It is widely used for building demolition, road breaking, tunneling, breaking steel slag, stone and crushing in quarries.

- 1) When crushing, make sure that the top point of the hammer is oriented perpendicular to the surface of the object to be broken, and maintain it as much as possible at all times, if it is inclined to the surface of the object, the hammer may slip away from the surface, in which case the hammer will be damaged.

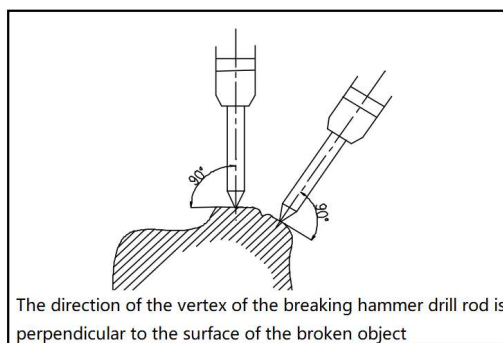

When breaking, select the appropriate strike point and make sure that the rod is secure before striking.

It is required that the bucket cylinder be adjusted at all times during operation to

keep the direction of penetration of the rod in a straight line with the body of the hammer.

- 2) When applying impact, press the brazing rod onto the impact surface so that the base plate is about 5cm above the ground, do not let the machine leave the ground too much.

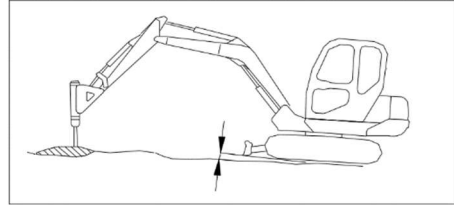

- 3) When applying continuous impact to the same impact surface, if the brazing rod does not penetrate or break the surface within one minute, change the impacting part and break the part near the edge.

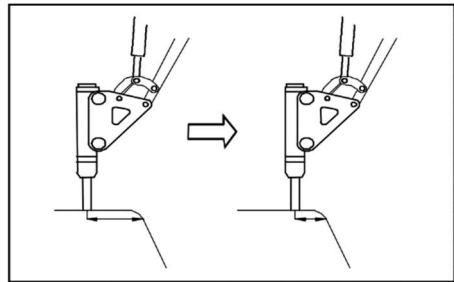

- 4) Keep the rod properly impacted on the surface to prevent empty strike.

When a rock or target has been broken, stop the hammer immediately. Continued aimless strikes will damage hammer, and may even damage the excavator itself.

If the hammer is not inserted properly, shaking the hammer will also cause damage.

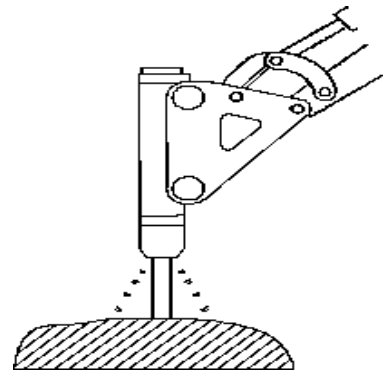

## **B. Wrong hydraulic hammer operation**

To ensure a long service life and safe operation of the machine, do not operate the machine in any of the following ways:

**ATTENTION: Do not operate all cylinders to the end of the cylinder stroke, always keep a margin of about 5cm.**

- 1) Use a crushing hammer to push heavy objects or large rocks.

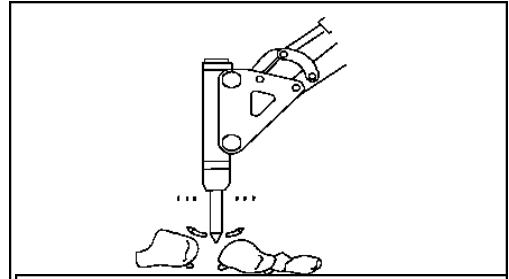

- 2) Operate with slewing force.

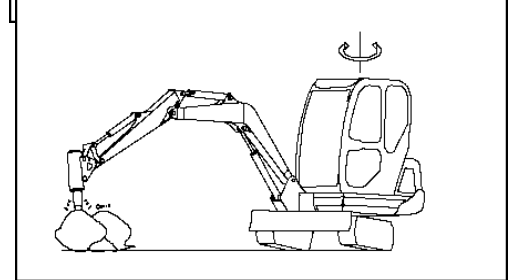

- 3) Move the crushing rod while performing impact operations

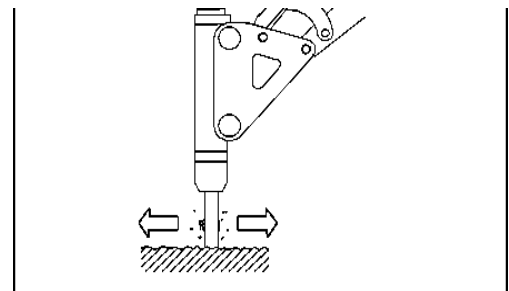

- 4) Apply impact force horizontally or to the top

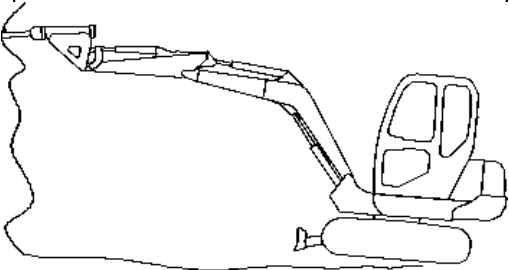

- 5) Swinging the crushing hammer when it has penetrated into the rock

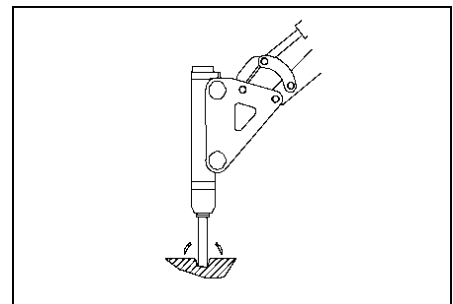

6) Pecking operation

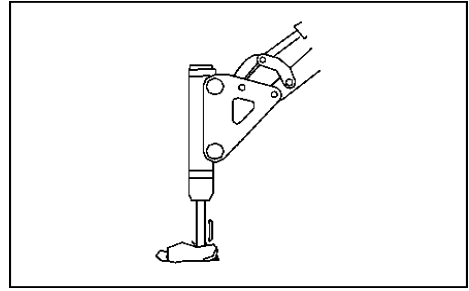

7) Crushing operation in water or muddy ground

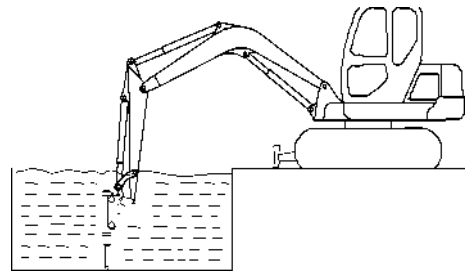

8) Using the crushing hammer as a tool for lifting heavy objects.

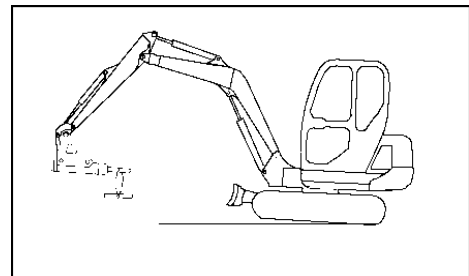

9) The bucket cylinder is fully extended to lift the machine off the ground.

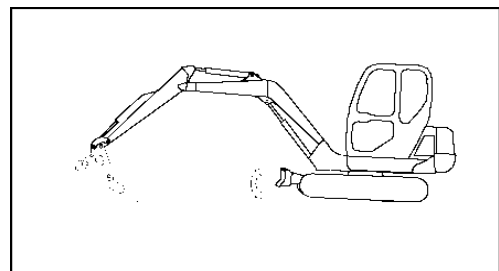



## 6.4. Daily inspection of hydraulic hammer

The following table carries out the daily inspection and maintenance of hydraulic breaker hammer.

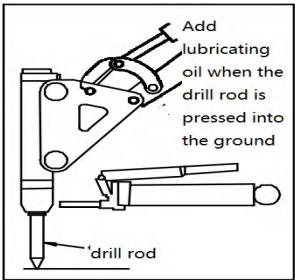
#	Inspection or maintenance items	Key parts	Maintenance method
1	Check bolts and nuts for looseness and loss	Main body bolts and side plate bolts	Tighten bolts or reinstall new bolts
2	Check for loose hose parts, broken hoses, and oil leaks	Break hammer hydraulic lines High-pressure hoses	Re-tighten loose parts and renew severely damaged parts
3	<p>Lubrication</p> 	<p>Before operation and after 2 to 3 hours of continuous operation, it is advisable to lubricate with 10ml/time of oil. Inject oil 5-10 times.</p>	<p>Inject oil through the oil injection hole in the front body of the hammer.</p>
4	Check the hydraulic oil capacity and pollution	Hydraulic oil	<p>A simple way to determine if the oil quality is changing is to observe if there is a change in the color of the oil. If the oil quality is deteriorating, drain the hydraulic oil from the hydraulic tank, clean the tank, and then fill it with new hydraulic oil.</p>

## 6.5. Quick coupler

### Installation

- 1) Pry up the pry bar①.

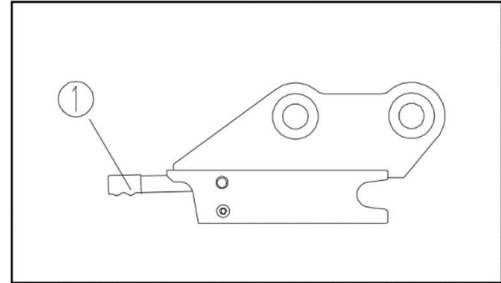

- 2) Put the bucket pin into②③, put down the pry bar, and the bucket is installed.

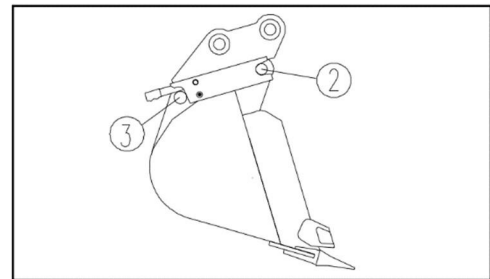

### Disamount

- 1) Use the pry bar to pry up ①.
- 2) Remove the bucket.

## 6.6. Grab Bucket

The grab bucket is used to dig or load on the side of a ditch or restricted space. It is suitable for basic works such as cleaning the sewer and unblocking the access opening of water and sewer.

### 6.6.1. Installation of grab bucket

- 1) First remove the bucket, bucket cylinder, connecting rod, rocker or other other attachments, etc. (as shown by arrows in Figure 1).

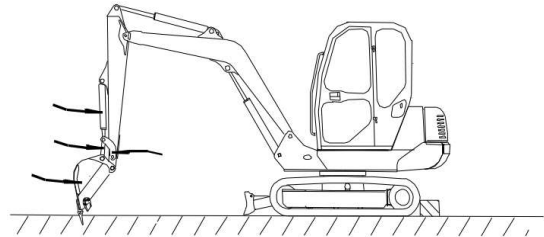

Fig. 1

- 2) Install the bucket directly on the bucket bar (as shown by arrow ① in Fig. 2).
- 3) The bucket pipeline assembly will be installed in the bucket body connection seat (as shown in Figure 2 arrow ②).

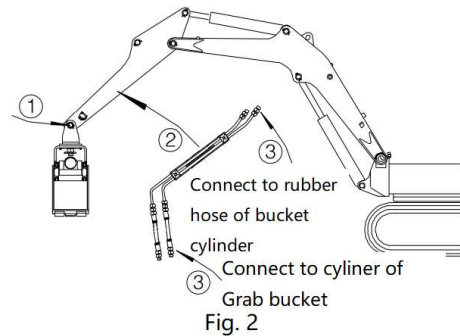

Fig. 2

- 4) Then the connect the original bucket cylinder piston oil inlet to the piston grab cylinder oil inlet, the original bucket cylinder rod oil inlet to the grab cylinder rod oil inlet (as shown in Figure 2 arrow ③).

### 6.6.2. Operation of the grab bucket

By operating the left joystick, you can control the arm to operate the far and near of the grab; by operating the right joystick, you can control the lifting and lowering of

the boom and the closing of the grab to carry out excavation work.

### 6.6.3. Operation precautions of the grapple

- 1) For safety reasons, avoid sudden travelling, turning and stopping of the machine.

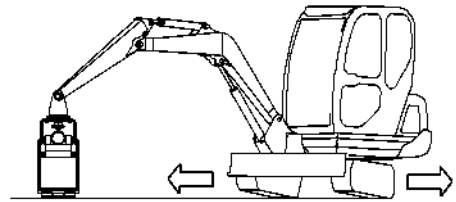

- 2) When digging, make the bucket teeth vertical to the ground.

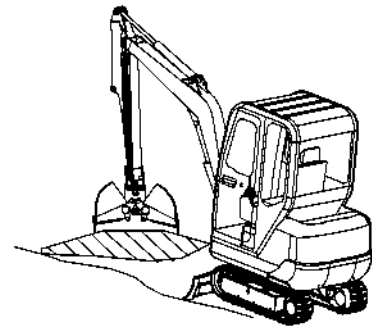

- 3) Don't use grapple to crush rock or down cut into the soil.

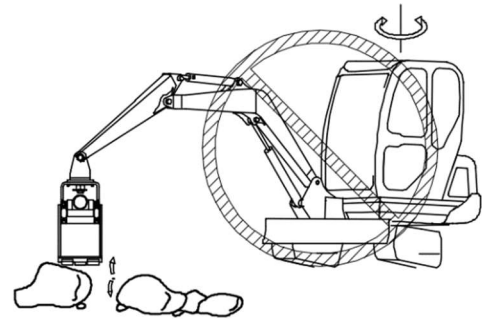

- 4) Don't use grapple to pile in or pulling pipe.

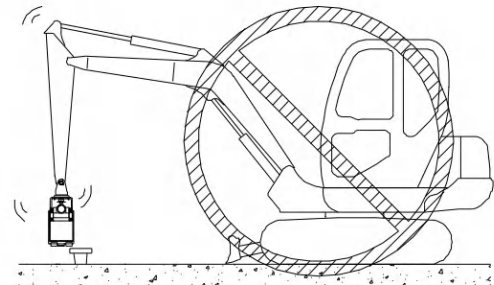

- 5) Open the grapple and put it on the ground before leave the machine

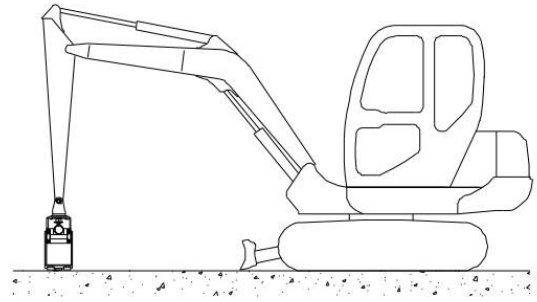

**ATTENTION: When transporting the machine, remove the grapple from the arm.**

#### 6.6.4. Maintenance of the grapple

- **Lubrication**

- 1) Park the machine on a hard horizontal surface, lower the working device to the ground, and turn off the engine.
- 2) Use the grease gun to inject grease into the grease nozzle as shown by the arrow on the right. (There are two grease nozzles on the left and right sides of the grab, and one grease nozzle on the pin connected to the arm)

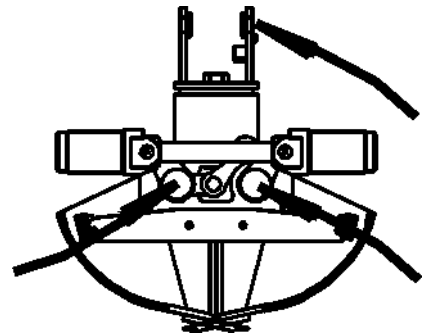

## 6.7. Drilling device

### 6.7.1. Installation of drilling device

- 1) Remove the bucket or other attachments.
- 2) Put the attachment on a flat place and connect the arm to the drilling unit and the connecting rod to the drilling unit with pin A and pin B in turn.

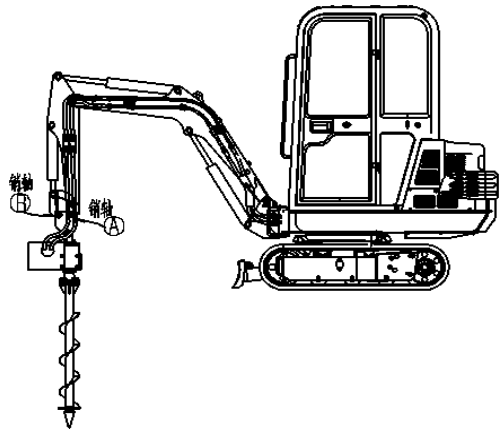

- 3) After confirming that the oil has cooled, remove the screws from the outlet and inlet respectively. Be careful not to allow dirt, mud, etc. to stick to the hose connection area. If the combination gasket is damaged, replace it with a new one.

- 4) Connect the attachment side hose. When connecting, check the direction of oil flow and be careful not to connect the wrong hose.

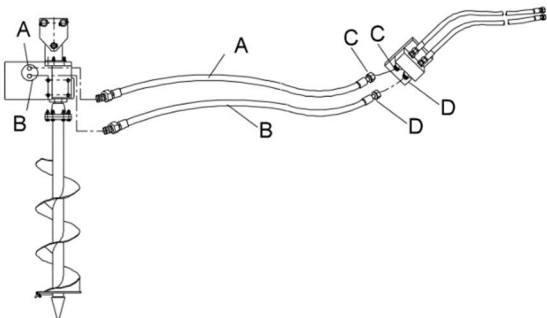

- 5) Unlock the rotary valves connected to the inlet and outlet pipes on the arm side.
- 6) After installing the attachment, make sure that the oil level in the hydraulic tank is at the proper position.

### 6.7.2. Operation of the drilling unit

- 1) Operate the joystick that controls the boom and arm, and lift the top of the drilling tool vertically. Operate the arm cylinder so that the drill head is lightly pressed against the ground and the front part of the machine is lifted so that pressure is applied to the drill head during the drilling process.

- 2) Press the auxiliary control pedal and start working (rotating) when the drilling tool reaches a certain depth.
- 3) If there is mud on the drilling tool, the mud will come off by reversing the drilling bit.

### 6.7.3. Precautions for the operation of drilling device

- 1) When drilling, make sure that the drill head is oriented perpendicular to the work surface and maintain the angle as much as possible at all times. When drilling, select the appropriate drilling point and make sure that the drill bit is stable before proceeding.

It is required that the bucket cylinder be adjusted at all times during operation to keep the direction of penetration of the drill tool in a straight line with the drill tool body.

- 2) If there is not enough depth, pull out the drilling tool first and then restart the operation.
- 3) The tip of the drilling tool attached to the machine should only be used for drilling in mud, never on stones.
- 4) Avoid pulling out the drilling tool when it is not rotating, as this will bend it.
- 5) When drilling, the drilling tool attachment should be vertical to avoid dislodging the drilling tool, which could damage the adjusting screws.
- 6) Never drill the drilling device in a crooked or oblique way.

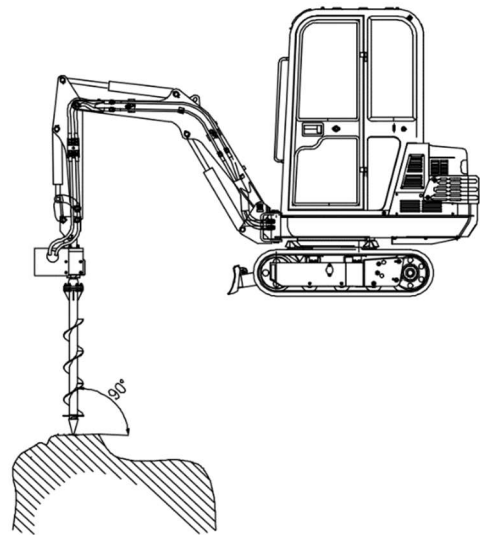

## 6.8. Backhoe bucket with scraper

### 6.8.1. Installation

Same with bucket

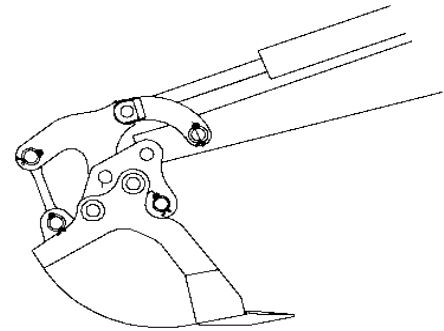

### 6.8.2. Operation of the backhoe bucket

Turn the right joystick to the right the backhoe bucket scraper will be closed inward and the backhoe bucket will be turned outward. When the joystick is turned to the left, the backhoe bucket scraper will be pushed outward and the backhoe bucket will be closed inward.

### 6.8.3. Maintenance of the backhoe bucket

Lubrication

- 1) Park the machine on a hard and level ground, lower the working equipment to the ground, and then turn off the engine.
- 2) Use the grease gun to fill the grease nozzle with grease. (As shown in the arrow on the right)

